

# UCD-323

# UCD-301

# UCD-340



## User Manual

UCD Console SW Version 2

## Copyright

This manual, Copyright © 2023 Unigraf. All rights reserved

Reproduction of this manual in whole or in part without a written permission of Unigraf is prohibited.

## Notice

The information given in this manual is verified in the correctness on the date of issue. The authors reserve the rights to make any changes to this product and to revise the information about the products contained in this manual without an obligation to notify any persons about such revisions or changes.

## Company Information

Unigraf

Piispantilankuja 4  
FI-02240 ESPOO  
Finland

Tel. +358 9 859 550

<mailto:info@unigraf.fi>

<https://www.unigraf.fi>

<http://www.unigraf-china.cn>

## Edition

UCD-3XX Console User Manual v2, Rev 13

Date: 9 February 2023

## Trademarks

Unigraf, UCD, UCD-300, UCD Console and TSI are trademarks of Unigraf Oy.

DisplayPort™ and the DisplayPort™ logo are trademarks owned by the Video Electronics Standards Association (VESA®) in the United States and other countries.

The Adopted Trademarks HDMI, High-Definition Multimedia Interface, the HDMI Logo, and HDMI Port Logo are trademarks or registered trademarks of HDMI Licensing Administrator, Inc. in the United States and other countries.

HDCP is a trademark of Digital Content Protection LLC.

Altera and Intel FPGA are trademarks of Intel Corporation or its subsidiaries in the U.S. and/or other countries.

Windows® 11, Windows® 10 and Windows® 8 are trademarks of Microsoft Corporation.

All other trademarks are properties of their respective owners.

## Limited Warranty

Unigraf warrants its hardware products to be free from defects in workmanship and materials, under normal use and service, for twelve (12) months from the date of purchase from Unigraf or its authorized dealer.

If the product proves defective within the warranty period, Unigraf will provide repair or replacement of the product. Unigraf shall have the whole discretion whether to repair or replace, and replacement product may be new or reconditioned. Replacement product shall be of equivalent or better specifications, relative to the defective product, but need not to be identical. Any product or part repaired by Unigraf pursuant to this warranty shall have a warranty period of not less than 90 days, from the date of such repair, irrespective of any earlier expiration of original warranty period. When Unigraf provides replacement, then the defective product becomes the property of Unigraf.

Warranty service may be obtained by contacting Unigraf within the warranty period. Unigraf will provide instructions for returning the defective product.

## CE Mark

UCD-300 family products meet the essential health and safety requirements, is in conformity with and the CE marking has been applied according to the relevant EU Directives using the relevant section of the corresponding standards and other normative documents.

## Table of Contents

	Copyright .....	2
	Notice.....	2
	Company Information.....	2
	Edition.....	2
	Trademarks.....	3
	Limited Warranty.....	3
	CE Mark .....	3
	Table of Contents.....	4
1.	About This Manual .....	7
	Purpose.....	7
	Product and Software Version .....	7
	Notes.....	7
2.	Introduction.....	8
	Product Description .....	8
	UCD-301 Digital .....	8
	UCD-323 HDDP and UCD-323 Gen2 .....	10
	UCD-340.....	12
	USB-C External Power Test Unit.....	15
	Safety and Operational Precautions.....	16
3.	Installation.....	17
	Installation Package .....	17
	Software Installation .....	17
	Firmware Installation .....	17
	Firmware Update Procedure.....	18
	Select Role.....	19
	Change Device Configuration .....	21
	License Manager.....	22
	UCD Console .....	24
	Options .....	25
	Detaching and Cloning Tabs .....	27
4.	Analyzer Operation .....	28
	Functionality Tabs .....	28
	Standard Tabs.....	29
	Video Tab.....	29
	Audio Tab.....	33
	EDID Tab.....	35
	HDCP Tab.....	36
	Source DUT Testing Tab.....	37
	DP and DP Alt Mode Reference Sink .....	39
	DP Link Tab.....	39
	DPCD Tab.....	43
	SDP Tab.....	44
	HDMI Reference Sink.....	45
	HDMI Link Tab .....	45
	InfoFrame Tab.....	48
	USB-C Monitoring .....	49
	USB-C Power Delivery Tab (PDC) .....	49
	Status List .....	50
	Capabilities .....	51
	DP Alt Mode.....	53
	Power Source .....	54
	Power Sink.....	55
	Cable Info.....	56
	Controls .....	56
	Bottom Panel.....	57

5.	Generator Operation .....	58
	Functionality Tabs .....	58
	Standard Tabs .....	59
	Pattern Generator Tab .....	59
	Playback Tab .....	62
	Audio Generator Tab .....	64
	HDCP Tab .....	65
	EDID Tab .....	66
	Sink DUT Testing Tab .....	67
	DP and DP Alt Mode Reference Source .....	69
	DP Link Tab .....	69
	DPCD Tab .....	73
	HDMI Reference Source .....	74
	HDMI Link Tab .....	74
	SCDC Monitor .....	76
	USB-C Monitoring .....	77
	USB-C Power Delivery Tab .....	77
6.	Event Log .....	78
	Logged Events .....	79
	Event Transaction List .....	81
	Customizing Transaction List .....	82
	Parsed Transactions .....	84
7.	EDID Editor .....	87
	Controls .....	87
	EDID Editor Features .....	88
	Editing Tips .....	88
8.	Packet Editor .....	89
	Introduction .....	89
9.	Pattern Editor .....	90
	Introduction .....	90
10.	Image Converter .....	92
Appendix A: Product Specification .....		93
	UCD-301 Digital .....	93
	UCD-323 HDDP .....	93
	UCD-323 Gen2 .....	94
	UCD-340 .....	94
Appendix B: Product Features .....		95
	UCD-301 and UCD-323 .....	95
	UCD-301 and UCD-323 (cont.) .....	96
	UCD-340 .....	97
	UCD-340 (cont.) .....	98
Appendix C: Predefined Timings .....		99
Appendix D: Predefined Patterns .....		100
	Fixed Patterns .....	100
	Extended Patterns .....	101
	Extended Patterns (contd.) .....	102
	Extended Patterns (contd.) .....	103
	Extended Patterns (contd.) .....	104

Appendix E: Sink and Source DUT Tests.....	105
DP Compliance Tests.....	106
Test Report .....	109
Audio Test Set – DP Rx, HDMI Rx .....	110
CEC Functional Test Set – HDMI Rx .....	111
CRC Based Video Test Set – HDMI Rx, DP Rx .....	112
Electrical Test Set – HDMI Rx.....	115
Electrical Test Set – DP Rx.....	117
Link Config Tests – DP Rx.....	119
Pixel Level Video Tests – DP Rx, HDMI Rx .....	120
USBC Electrical Test Set – DP Rx, DP Tx.....	121
VRR Source DUT Tests – HDMI Rx .....	125
VRR Sink DUT Tests – HDMI Tx.....	126
Appendix F: Vpattern Language .....	127
General .....	127
Commands.....	128
Variables .....	134
Appendix H: Playlists and Scenarios.....	136
Playlists .....	137
Scenarios .....	138
Parameters.....	138
Example .....	141
Sample Content in Playback Tab .....	143
Playlist: Basic Video & Audio Example .....	144
Playlist: HDR & Metadata Example .....	145
Playlist: VRR Example (HDMI) .....	146
Playlist: Frame Rate Example (DP) .....	149
Playlist: ALLM (HDMI) .....	150

# 1. ABOUT THIS MANUAL

## Purpose

This guide is User Manual of UCD-301, UCD-323 and UCD-340, USB-connected video interface test units for use with a PC with Windows® 11, Windows® 10 or Windows® 8 operating system.

The purpose of this guide is to

- Provide an overview of the products and their features.
- Provide instructions for the user on how to install the software and the drivers.
- Provide instructions for the user on how to update the FW of the unit.
- Introduce the HW features of the units.
- Provide instructions for the user on how to use UCD Console software.

## Product and Software Version

This manual explains features found in UCD Console Software Bundle **2.4**. Please consult Unigraf for differences or upgrades of previous versions.

Please consult the Release Notes document in the installation package for details of the SW and FW versions and changes to previous releases.

## Notes

On certain sections of the manual, when important information or notification is given, text is formatted as follows. Please read these notes carefully.

---

**Note:** This text is an important note

---

---

**Note:** This version of the User Manual describes features in UCD Console software version 2 based on the functionality in Microsoft Windows operating system.

UCD Console is available also for macOS operating system to be used in iMac and MacBook computers and for Linux operating system.

Detailed description of the macOS and Linux versions will be added later.

---

## 2. INTRODUCTION

### Product Description

UCD-300 family are high speed, USB 3.0 connected video interface test unit. UCD-300 series consists of the following units:

UCD-301	DisplayPort 1.4 and HDMI 2.0 analyzer
UCD-323	DisplayPort 1.4 and HDMI 2.0 analyzer and generator
UCD-340	USB-C DisplayPort Alt Mode analyzer and generator
USB-C External Power Test Unit	Accessory to UCD-340 for testing Power load for USB-C Sink or Source DUT.

*UCD Console* is user interface (GUI) for UCD family test equipment for desktop use. The outlook and details of UCD Console will vary depending on the capabilities of the connected unit and will reflect the features enabled.

Unigraf UCD units feature a high-level Software Development Kit (SDK) called Test Software Interface (TSI) for use in automated testing. TSI allows for an easy integration of Production and R&D testing routines into an automated test system environment. Please refer to TSI documentation found in additional Unigraf manuals for more details.

### UCD-301 Digital

#### Product Features

- Support for HDMI 2.0 and DP 1.4 display interface
- High resolution video and audio capture up to up to 4K / UHD 60 Hz
- Compatible with HDCP versions 1.3 / 1.4 and 2.2 / 2.3
- 2 GB on-board high-speed video buffer
- High speed USB 3.0 host PC interface

#### Functional Description

UCD-301 units consist of a multimedia signal input stage, a control stage with on-board frame buffer and a PC interface stage. In the Input Stage the signal is conditioned and converted to desired format. The Interface and Control stages are either passing the captured data directly to the USB interface or storing it to the frame buffer. Interface & Control stages are receiving instructions from the host PC to configure and control the functionality of the unit.

Please find below logical diagram of UCD-301 unit

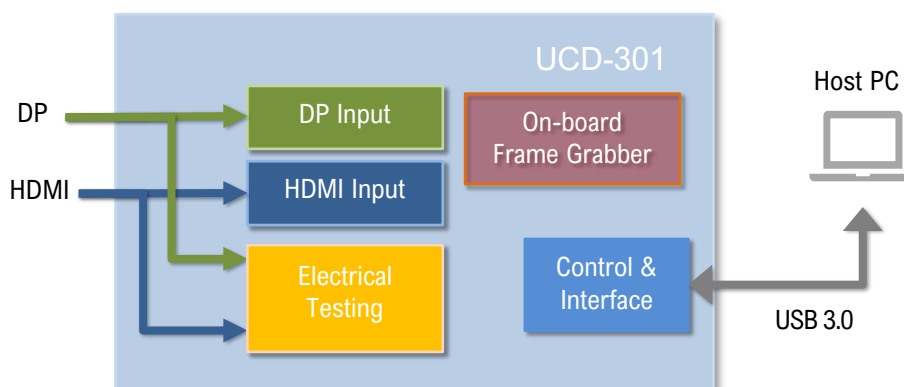



## Delivery Content

UCD-301 product shipment contains:

- The UCD-301 unit
- AC/DC Power supply (100 to 240 Vac 50/60 Hz input, +12 Vdc output)
- USB 3.0 compliant cable

## Connections

The image below indicates the connections in UCD-301 unit and their description

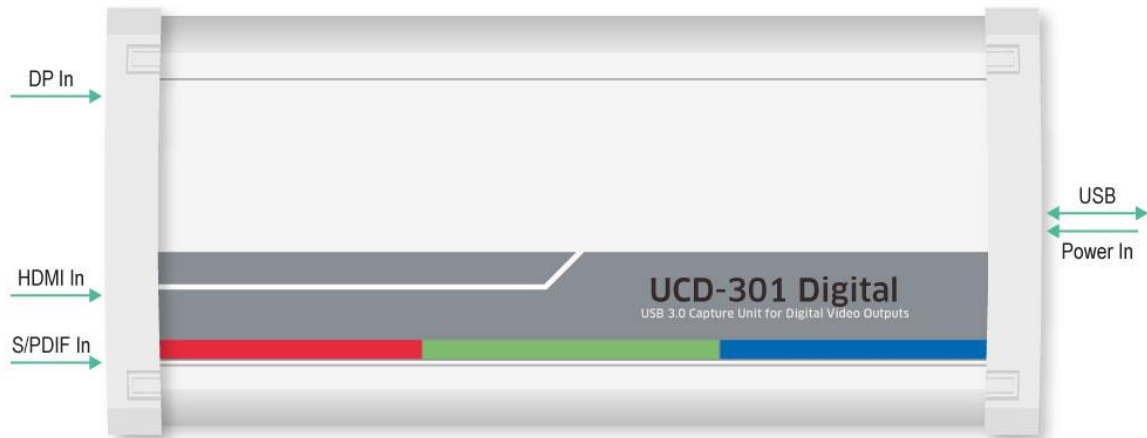

Name	Description
DP In	DisplayPort 1.4 compliant input from the upstream Source
HDMI In	HDMI 2.0 compliant input from the upstream Source
S/PDIF In	Test input for ARC Function
Power In	+12 Vdc Power Supply Input
USB	USB 3.0 connection to the host PC

## UCD-323 HDDP and UCD-323 Gen2

### Product Features

- High resolution video and audio capture up to up to 4K / UHD 60 Hz
- Support for multiple display interfaces including HDMI 2.0 and DP 1.4
- Compatible with HDCP versions 1.3 / 1.4 and 2.2 / 2.3
- UCD-323 HDDP 2 GB (optionally 4 GB), UCD-323 Gen2 4 GB on-board video buffer
- High speed USB 3.0 host PC interface

Please refer to *Product Specifications* in the appendix of this document for details.

### Functional Description

UCD-323 units consist of a multimedia signal input stage, an internal pattern generator, a control stage with on-board frame buffer and a PC interface stage. In the Input Stage the signal is conditioned and converted to desired format.

The Interface and Control stages are either passing the captured data directly to the USB interface or storing it to the frame buffer.

The internal pattern generator is able to source a signal for testing sink and branch units. The Interface & Control stages are receiving instructions from the host PC to configure and control the functionality of the unit.

### AUX Controller for PHY CTS

UCD-323 Gen2 is a companion tool for PHY test equipment to perform automated DP 2.0 PHY compliance testing for Source and Sink DUT. AUX controller is supported using Unigraf TSI API.

Please find below logical diagram of UCD-323 unit

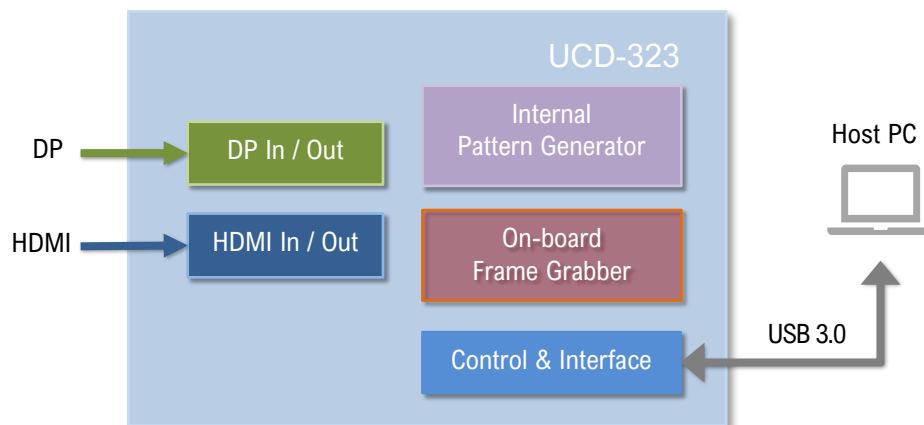

### Delivery Content

UCD-323 product shipment contains:

- The UCD-323 unit
- AC/DC Power supply (100 to 240 Vac 50/60 Hz input, +12 Vdc output)
- USB 3.0 compliant cable

## Connections

The image below indicates the connections in UCD-323 unit and their description

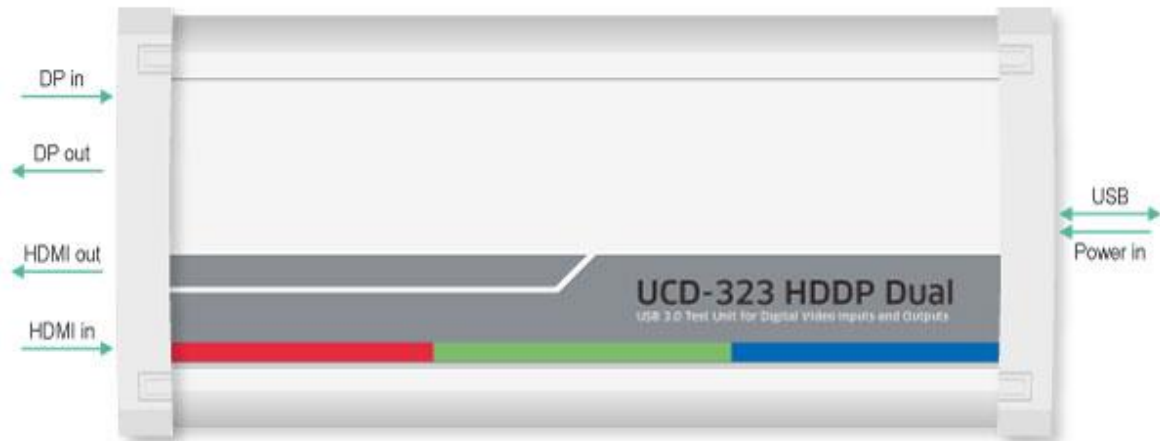

Name	Description
DP in	DisplayPort™ 1.4 compliant input from the upstream Source
DP out	DisplayPort™ 1.4 compliant output to the downstream Sink
HDMI in	HDMI 2.0 compliant input from the upstream Source
HDMI out	HDMI 2.0 compliant output to the downstream Sink
Power in	+12 Vdc Power Supply Input
USB	USB 3.0 connection to the host PC

## UCD-340

### UCD-340 Product Features

- Test unit for testing power delivery and DP Alt Mode functions of USB-C interface
- Monitoring and control of data and power delivery roles of the USB-C interface
- Optional Power Test Unit for testing high voltage and power options

Please refer to *Product Specifications* in the appendix of this document for details.

### Functional Description

UCD-340 is an integrated test unit for verifying the performance of PD and DP Alt Mode functions in a USB Type-C device.

UCD-340 unit consist of a USB-C signal input stage with data multiplexer with either two directional data pass-through to USB2 or USB3 interfaces or connection to DP Alt Mode input / output block.

The USB-C input stage consists of capability for electrically testing the continuity of input signals. An optional separate Power Test unit is sourcing or sinking the various voltages for testing USB-C power options.

The DP Alt Mode block includes frame grabber and pattern generator functions for emulating DP Alt Mode source and sink functions.

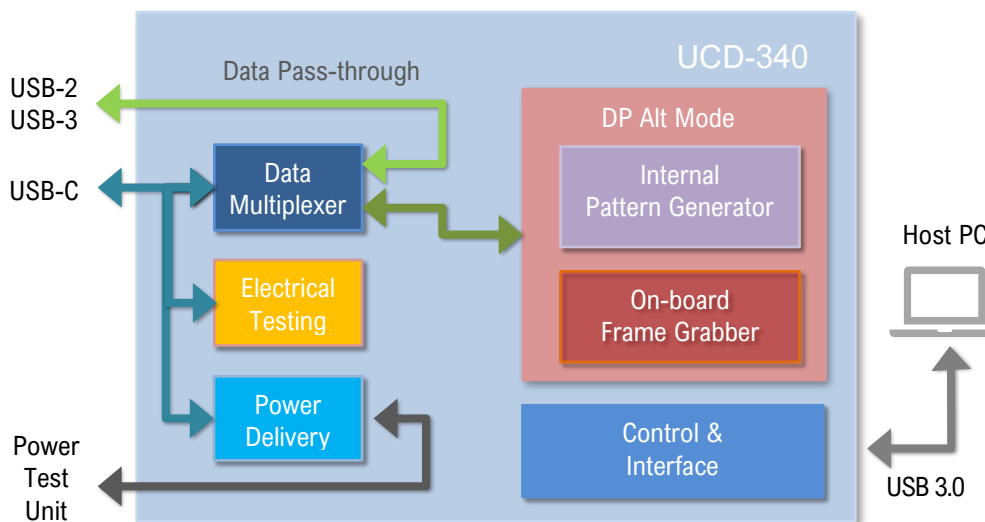

### Delivery Content

UCD-340 product shipment contains:

- The UCD-340 unit
- AC/DC Power supply (100 to 240 Vac 50/60 Hz input, +12 Vdc output)
- USB 3.0 compliant cable
- USB-C to USB-C test cable
- Unigraf Electrical test cable (with units including Electrical Test)

## UCD-340 Connections

The image below indicates the connections in UCD-340 unit and their description

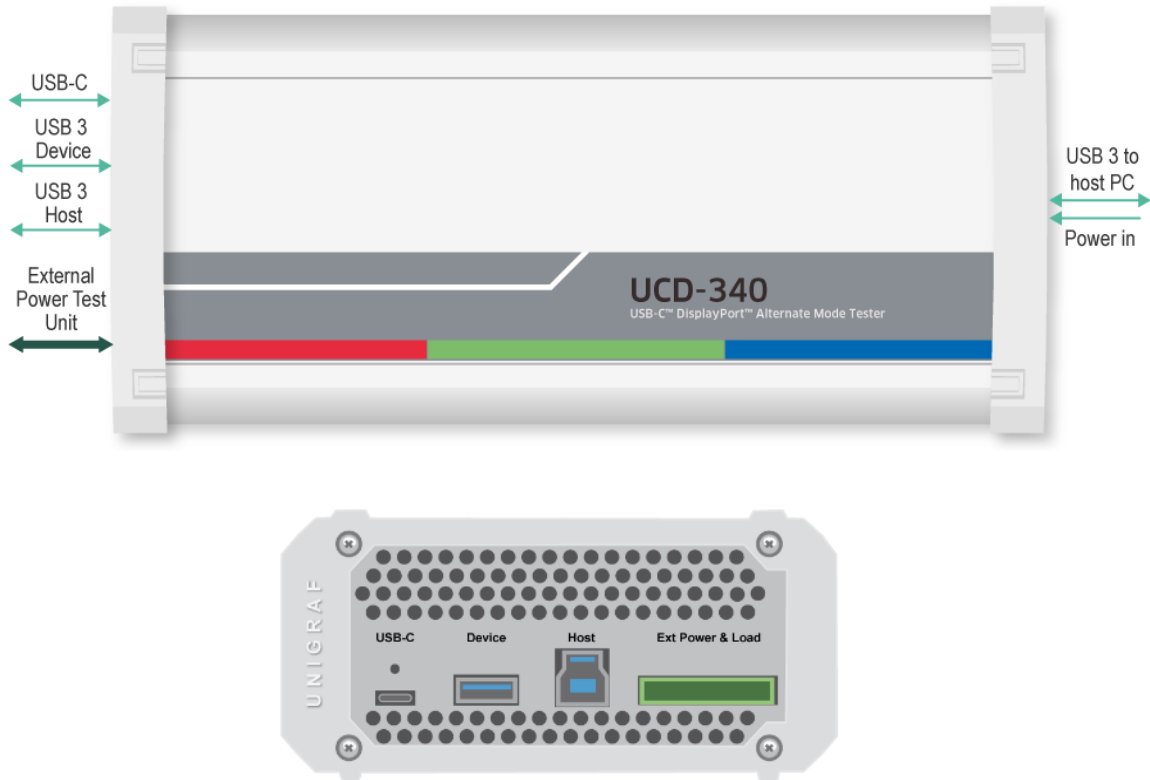

Name	Description
USB-C	USB Type-C Connection to the evaluated device (DUT)
USB 3 Device	USB Type-A connector for an auxiliary USB 3.1 "Device" for data pass-through
USB 3 Host	USB Type-B connector for an auxiliary USB 3.1 "Host" for data pass-through
External Power Test Unit	Connector for Unigraf's "USB-C External Power Test Unit"
Power in	+12 Vdc Power Supply Input
USB 3 to host PC	USB 3.0 connection to the controlling PC

**Note:** Capturing and sourcing high resolution video modes, especially 4K video modes set stringent requirements on the video cables and connectors. Please contact Unigraf for assistance and details about evaluated cables.

**Warning** In order to avoid possible damage to the UCD unit and the PC, please **always attach the power cord (Power In) to UCD-300 unit first**, and after that connect the USB cable to your PC.

## Unigraf Electrical Test Cable to UCD-340

Some features of the Electrical Test function in UCD-340 are available only when using the special Electrical Test Cable provided by Unigraf. Electrical Test Cable includes extra wires enabling UCD-340 to individually measure the electrical continuity of DUT's four VBUS and four GND signals that are normally tied together at DUT's end of the cable. Please refer to the image below for clarification.

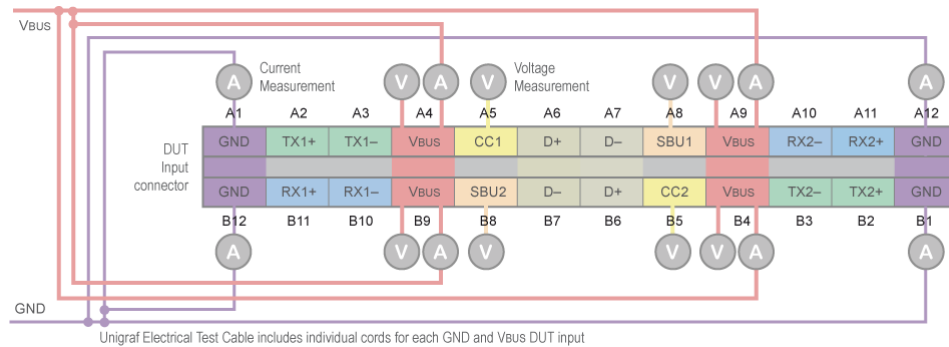

**Note:** When attaching Unigraf Electric Test Cable, please make sure that the finger-screw is tightened all-the-way into its hole. When tightened, the finger-screw triggers a switch indicating the presence of Unigraf Electric Test Cable.

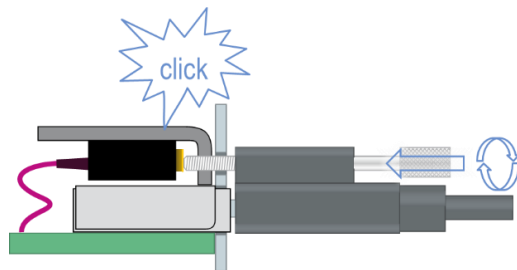

You can also verify that Unigraf Test Cable is plugged from UCD Console by selecting vertical Tab **USB-C**, horizontal tab **Roles and Modes**. The indicator text can be found in the bottom bar.

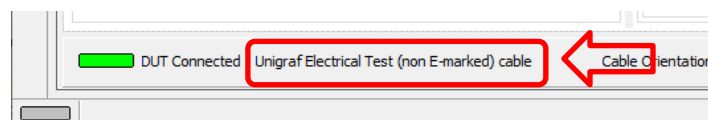

### Two Electrical Test Cable Types

Please note that there are two versions for Unigraf Electrical Test Cable. The difference is the number of USB D+/- pairs included in the cable.

- If DUT has shorted USB2.0 pins A6 to B6 and A7 to B7 at the receptacle then choose cable One: In order to minimize in-cable signal coupling only one USB D+/- pair is included in the cable.
- If DUT has shorted USB2.0 pins routed to mux or similar, then choose cable Two: In order to enable electrical cable flip in cases where USB D+ lines and USB D- lines correspondingly have not been shorted together on Device side, both USB D+/- pairs are included in the cable. This cable marked with a label "2xUSB 2.0 PAIRS".

## USB-C External Power Test Unit

Unigraf *External USB-C Power Test Unit* connected to UCD-340 enables testing extended USB power options. Please find below a matrix describing Power Source and Power Sink options of UCD-340 internally and with attached *Unigraf External Power Test Unit*. Please find description of controlling the power options with UCD Console later in this manual.

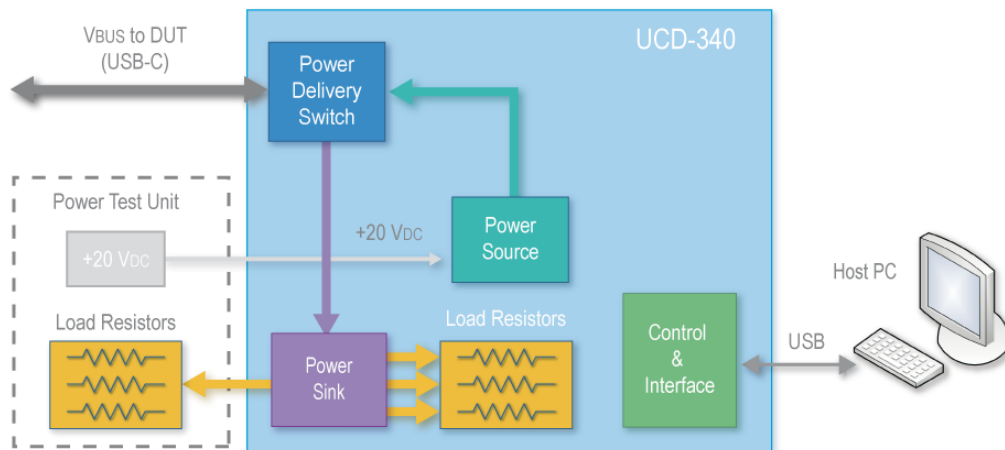

### Power Test Capability

The table below indicates which Vbus voltages and current ranges are available with UCD-340 only and which with UCD-340 combined with USB-C External Power Test Unit

Used equipment:	5 V				9 V	12 V	15 V	20 V
	0.5 A	0.9 A	1.5 A	3 A	3 A	3 A	3 A	5 A
<b>Vbus Source capability</b>								
UCD-340	•	•	•	•				
UCD-340 with USB-C External Power Test Unit	•	•	•	•	•	•	•	•
<b>Vbus Sink capability</b>								
UCD-340	•	•	•	•				
UCD-340 with USB-C External Power Test Unit	•	•	•	•	•	•	•	•

## Safety and Operational Precautions

Please find below the **Safety Precautions** for using the Unigraf UCD test instrument. Please also carefully read the **Notes and Warnings** within the text of this manual.

These **Precautions and Warnings** are provided to enable a safe use of the UCD test equipment. Therefore, Unigraf assumes no liability when the user fails to follow the expressed **Precautions and Warnings**.

- Use only Unigraf provided AC/DC Power Adapter. Please make sure that connectors and cabling to the Power Adapter are intact. In case there are any doubts about the condition of the Adapter or cabling, stop using it immediately.
- It is important to ensure that the used AC input voltage is within the specified range (100 to 240 Vac 50/60 Hz) and the fuses in the AC lines are of the specified type. If in doubt, do not connect the device.
- When installing the unit, connect the Power Adapter to the UCD device first, after that connect the AC plug. Please disconnect the USB cable to the controlling PC and remove cabling to DUT while connecting the power input cables.
- It is forbidden to open the housing of the UCD device without a written permission from Unigraf. Failure to comply with this rule will void the warranty of the unit.
- UCD devices are intended for use as Electrical Test Instrument only. Use for other purposes is forbidden.
- Use UCD equipment only in its specified ambient temperature and humidity.
- In order to ensure that the UCD device and associated SW will operate properly, please ensure that the PC used for controlling the UCD device complies with the minimum requirement set by Unigraf.
- Please keep UCD software updated by regularly checking the updates on Unigraf download page (<https://www.unigraf.fi/downloads/>). Please update the device firmware to match the installed software.



## 3. INSTALLATION

### Installation Package

The UCD software installation package can be obtained from Unigraf download page at <https://www.unigraf.fi/downloads/>

The installation package is a bundle between the components needed for UCD Console and for TSI SDK. The bundle contains the following items:

- Windows drivers (installed during set up)
- UCD Console software (installed during set up)
- License Manager (installed during set up)
- Device configuration utility (installed during set up)
- Packet Editor (installed during set up)
- Pattern Editor (installed during set up)
- TSI SDK (installed during set up)
- User Manuals including this document.

---

**Note:** The software should be installed before connecting the UCD unit to the PC.

---

---

**Note:** System administrator's privileges are required for performing the installation.

---

### Software Installation

- ▶ Start the installation by running application **SoftwareBundle\_X.X.XXXX** (X.X.XXXX denotes the installed software version)

Once the installer has started, a welcome page is displayed. The welcome page shows the software package release version.

The user is also asked to confirm

- Creating a desktop shortcut
  - Installation of Visual C++ redistributable
  - Installation of Unigraf USB drivers
- ▶ Next dialog confirms the selections made. If you are ready, click Install to start the installation.
  - ▶ Click **Finish** to exit the installation dialog.

### Firmware Installation

Along with the change to UCD Console software version 2, Unigraf is restructuring the software (SW) builds and releases. For the time being we are releasing firmware (FW) packages separately from SW for UCD product families. This means that SW installation **does not** automatically install the new FW package.

After software installation is completed, please download the **FirmwarePackage\_X.X.XXXX** (X.X.XXXX denotes the installed firmware version) also available on Unigraf download page <https://www.unigraf.fi/downloads/> and run the included application.

New firmware files will automatically be copied to the correct location in the PC. Please follow instructions in *Firmware Update Procedure* below to update firmware in the UCD device.

## Firmware Update Procedure

UCD Configuration Utility is used to load an updated firmware to the device. As an option, UCD Configuration Utility can be used to select possible alternative operation roles for the UCD unit. A firmware set for the selected operation roles is created and the firmware set is programmed to the device. Please contact Unigraf for details.

**Note:** Firmware update is a sensitive process. Please do not disconnect the device from the PC and do not power it off before the operation is completed unless specially requested. Avoid plugging and unplugging other USB devices when the firmware update is in progress.

To update the firmware or create a new configuration on a UCD device, please perform the following steps:

- ▶ Connect the UCD unit to a power supply and connect the USB cable.
- ▶ Open UCD Console. Select Tools > Firmware Update.

The first page of the utility indicates the firmware component versions present in the package. Please click **Next**.

From the list of connected UCD devices please select the one that you want to update. Click **Next**.

### Updated Modules

The tool lists the FW components available in the UCD device, the currently programmed FW version, and the FW installed in the PC for programming.

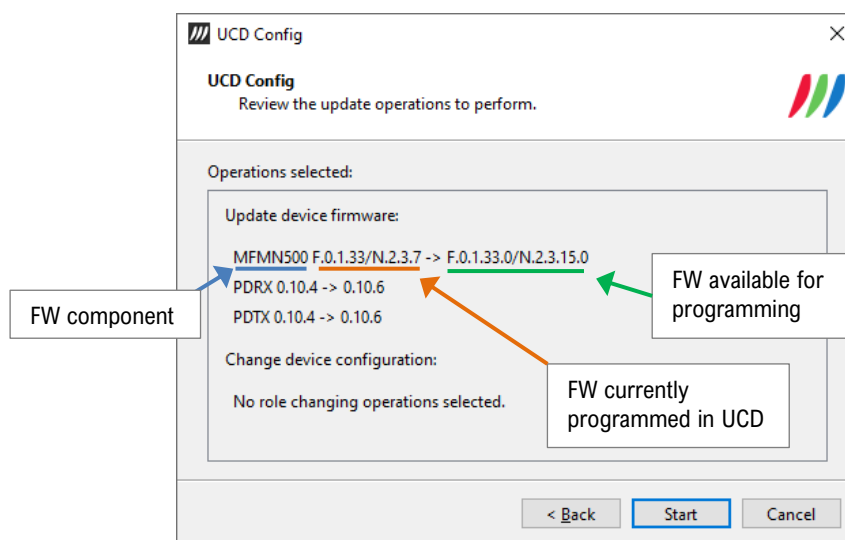

- ▶ Click Start to start programming.

### Power Cycle

When re-initiating the firmware of a UCD device the whole process cannot be done during one session. Therefore, on certain point, user needs to power cycle the device (switch off power from UCD device > wait for 10 seconds > re-apply power to UCD device).

Click **OK** button on the dialog.

**Note:** The procedure may take several minutes depending on the speed of the USB connection of the host PC.

## Select Role

The use of UCD-300 devices with UCD Console is divided in display interface specific roles. The structure of UCD Console varies between roles by having a varying set of tabs dedicated to functionalities available in the enabled role. The table below lists the roles and tabs available in each role. Please find a detailed description of each role in the later chapters of this manual. Please find a description on changing device configuration later in this document.

Each UCD-300 model features a unique set of modes available. In special occasions, Unigraf can create custom configurations. Please contact Unigraf Support for details.

### Available Mode Configurations for UCD-301

In addition to the separate HDCP 2.3 enabled HDMI and DP Reference Sink roles, in UCD-301 you can select a combined mode where three roles are available in one configuration.

Role	Tabs available
HDMI Reference Sink (HDCP 2.3)	Video preview and saving (Video). Audio monitoring and saving (Audio). Status information and control of the upstream link (Link). EDID editor (EDID). HDCP 1.4 and 2.3 status monitor and control (HDCP). Monitor InfoFrame data (InfoFrames). Executing TSI Test cases (Source DUT Testing).
DisplayPort Reference Sink (HDCP 2.3)	Video preview and saving (Video). Audio monitoring and saving (Audio). Status information and control of the upstream link (Link). EDID editor (EDID). DPCD editor (DPCD). HDCP 1.3 and 2.3 status monitor and control (HDCP). Monitor Secondary-Data Packets (SDP) Event log (Event log) Executing TSI Test cases (Source DUT Testing). Executing HDCP 2.3 CTS Tests (Source DUT Testing).
Combined Mode	
HDMI Reference Sink	Video preview and saving (Video). Audio monitoring and saving (Audio). Status information and control of the upstream link (Link). EDID editor (EDID). HDCP 1.4 status monitor and control (HDCP). Read InfoFrame data (InfoFrames). Executing TSI Test cases (Source DUT Testing).
DisplayPort Reference Sink	Video preview and saving (Video). Audio monitoring and saving (Audio). Status information and control of the upstream link (Link). EDID editor (EDID). DPCD editor (DPCD). HDCP 1.3 status monitor and control (HDCP). Executing TSI Test cases (Source DUT Testing).

## Available Mode Configurations for UCD-323

Role	Tabs available
HDMI Reference Sink (HDCP 2.3)	Video preview and saving (Video). Audio monitoring and saving (Audio). Status information and control of the upstream link (Link). EDID editor (EDID). HDCP 1.4 and 2.3 status monitor and control (HDCP). Monitor InfoFrame data (InfoFrames). Executing TSI Test cases (Source DUT Testing).
DisplayPort Reference Sink (HDCP 2.3)	Video preview and saving (Video). Audio monitoring and saving (Audio). Status information and control of the upstream link (Link). EDID editor (EDID). DPCD editor (DPCD). HDCP 1.3 and 2.3 status monitor and control (HDCP). Monitor Secondary-Data Packets (SDP) Event log (Event log) Executing TSI Test cases (Source DUT Testing). Executing HDCP 2.3 CTS Tests (Source DUT Testing).
HDMI Reference Source (HDCP 2.3)	Video pattern generator (Pattern Generator). Status information and control of the downstream link (Link). EDID editor (EDID). HDCP status monitor and control (HDCP).
DisplayPort Reference Source (MST – 2 streams, HDCP 2.3)	Video pattern generator 2 stream MST (Pattern Generator). Status information and control of the downstream link (Link). EDID editor (EDID). DPCD monitor (DPCD) HDCP status monitor and control (HDCP).
DisplayPort Reference Source (SST, HDCP 2.3)	Video pattern generator with custom patterns and SST (Pattern Generator). Status information and control of the downstream link (Link). EDID editor (EDID). DPCD monitor (DPCD) HDCP status monitor and control (HDCP). Executing HDCP 2.3 CTS Tests (Sink DUT Testing).

A full description of the functions and the licensing can be found in [Appendix B Licensing](#).

## Change Device Configuration

UCD-300 devices can feature four simultaneous interface Roles (please refer to *UCD Console > Select Role below*). Changing the role configuration is done by selecting the firmware packages loaded to the UCD-300 device. For selecting you need to open *UCD Firmware Configuration* utility in a special mode. The easiest way is to create a batch file with Notepad (e.g. config.bat) with the following content:

► ucdconfig config

In the special mode, you will be able to initiate the configuration dialogs. For that, select **Change device configuration** check box.

In the third dialog *UCD Device Roles* select the four roles that you prefer to be available in *UCD*

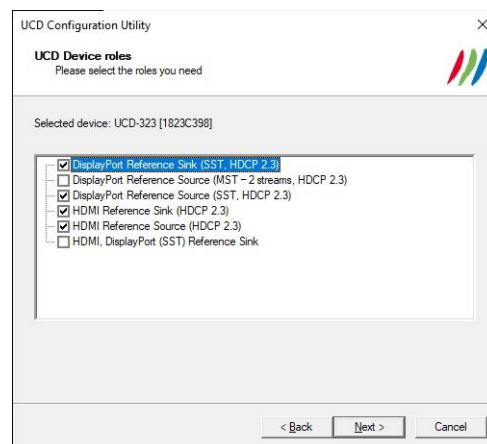
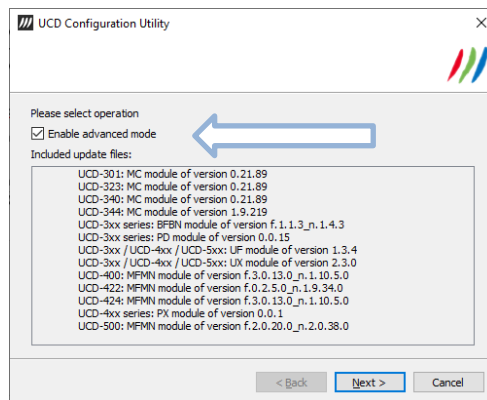

*Console*. After selection, please click **Next** to proceed to firmware update.

# License Manager

## Licensing

The features of UCD Console GUI are divided into groups based on the target use of the device. Most basic features can be used by default, and more advanced feature groups are enabled by dedicated licenses. When the licenses are present, the related part of the GUI will be shown, or the related control will be enabled.

Unigraf licenses are provided as strings of characters, **License Keys**. Each License Key enables a dedicated function in one device. Each device has its dedicated **Seed Number**. Each **License Key** is tied to one **Seed Number**. License Keys can be freely used in any number of PCs.

License keys are managed with **UCD License Manager**. License manager can be found in the **Tools** menu of UCD Console 2.

---

**Note:** System administrator's privileges are required for accessing the licenses.

---

## License Manager GUI

When run, License Manager will list the licensing enabled Unigraf devices. In the list of Devices please **Select** the device in question. The *serial number* and the *seed number* of your device are printed in a sticker attached to the bottom of the device.

The **Rescan...** button will re-scan the system for installed hardware.

## Managing Licenses

### Seed Number

Each license is tied to a hardware unit with the help of the **Seed Number**. Each unit has a unique Seed Number. Seed Number of the selected unit can be found in the top of the dialog.

Seed Number of the selected device can be copied from dialog link for e.g., ordering Licenses.

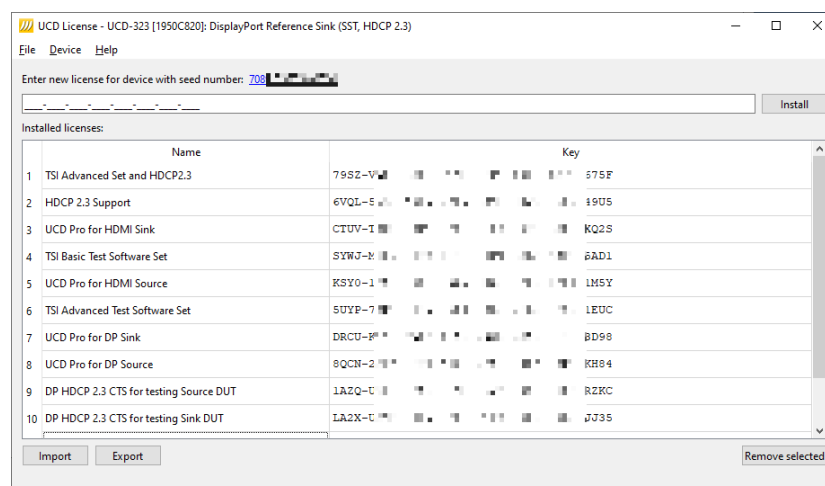

### Adding New License Keys

To add a new license key for a device, please enter the characters from the license sticker to the field for new licenses. The License Manager will automatically move the caret across the edit boxes during typing. If the key is given in text format, copy it and paste to the leftmost box.

Once the license key is fully entered, click the **Install**. The license is authenticated and if it is valid, the license will appear in the list of installed licenses. If the key fails to authenticate, an error message is displayed. If this happens, please make sure that the key has been typed correctly and that the seed number on the license key sticker matches the seed number displayed in UCD License Manager.

Please note that to avoid confusion, some letters will never appear in a license key because they resemble numbers: For example, capital 'G' and number '6' are very similar when printed with small font. When in doubt, use numbers.

Also, please notice, that characters that cannot be part of valid license key are not accepted as input. When appropriate, an automatic conversion is applied while typing: For example, lower case letters are converted to upper case automatically.

### Managing Installed Licenses

The Installed licenses list shows all installed licenses for the selected device. The list shows the name of the license and the actual license key characters.

**Remove Selected** will uninstall selected licenses. To uninstall a license, click on the license and then click the Remove Selected button.

**Export** will allow installed licenses for the currently selected device to be saved into an INI file for backup and distribution to other PCs. To export license(s), click on the license(s) and then click the Export button. Please notice that licenses from multiple devices can be exported into the same INI file.

**Import** will install licenses from an INI file for the currently selected device.

## UCD Console

*UCD Console Version 2* is the 2<sup>nd</sup> generation graphical user interface (GUI) for UCD family test equipment for desktop use. UCD Console provides the user access to all features of the unit. UCD Console also includes powerful debugging and analysis tools enabling the user to monitor the status of the display interfaces and assist in the problem detection.

The various features of the UCD unit are divided into interface specific screens and tabs. Each tab contains data and controls for a specific feature.

**Note:** This version of the User Manual describes features in UCD Console 2 based on the functionality in Microsoft Windows operating system. UCD Console 2 will be available also for macOS operating system to be used in iMac and MacBook computers and for Linux operating system. Detailed description of the macOS and Linux versions will be added later.

## Device Selection

A shortcut of UCD Console can be found by default under Start Menu.

Once UCD Console GUI is launched, the dialog provides a list of Unigraf UCD devices connected in the PC. Please select the target device by clicking on the appropriate button. If your device cannot be found in the list, please confirm the power and USB connection to the device and click the **Rescan ...** button.

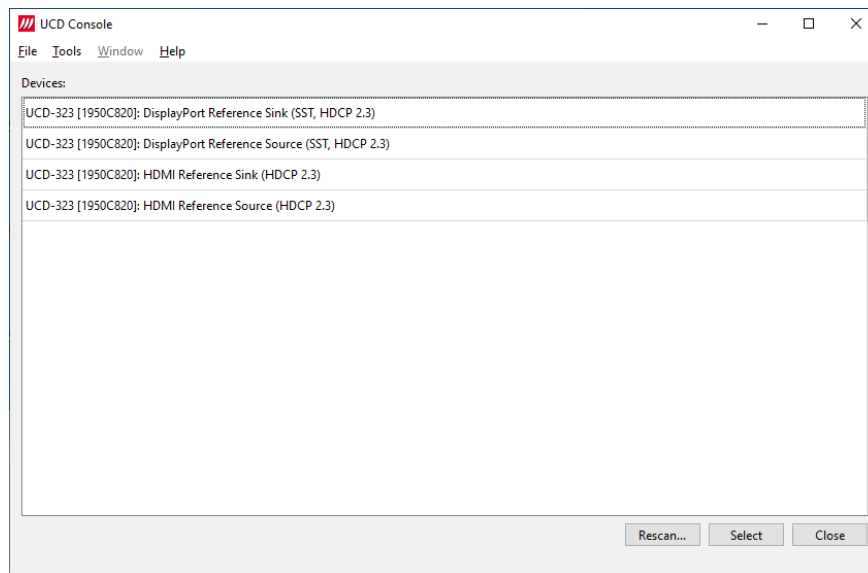

## Analyzer and Generator Operation

Most UCD devices can be used with UCD Console as Analyzer (a Sink device) and as Generator (a Source device). In default configuration UCD-300 family devices can operate in one role at a time.

The operating role is selected when the device is opened in UCD Console. For changing a role, please close the device (File > Close Device), click Rescan ... if needed, and select the new role.

This User Manual will explain all roles available for UCD-300 devices and the functionalities available for each role.



## Options

Options can be found in **Tools > Options**.

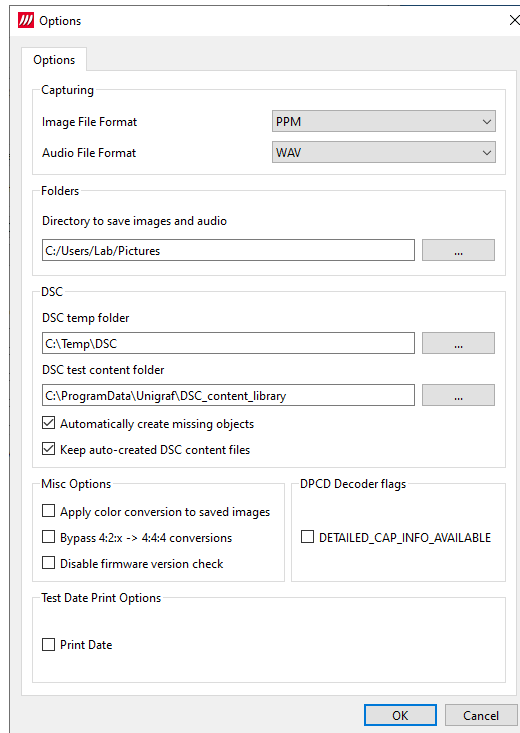

### Image File Format

You can save the captured frames either in PPM, BMP, JPG or PNG bitmap file format. In PPM format the files are stored with the captured color depth, with other formats the color depth is truncated to 8 bits per color.

### Audio File Format

Audio files are stored in WAV format

### Folders

Please select the directories in the PC for saving the captured images and audio, the saved Presets and DSC test content and DSC Work directories.

### DSC

<i>DSC temp folder</i>	Folder for DSC Work files.
<i>DSC test content folder:</i>	Folder where DSC source bitmap files, related configuration files and DSC conversion tools are stored.
<i>Automatically create missing content</i>	When selected, compliance test tool During execution of DSC Compliance Tests, the tool automatically creates the DSC compressed content used for testing the DUT.
<i>Keep auto-created</i>	By default, the DSC compressed content is deleted after use. If selected, the content is not deleted

#### Warning

Keeping the automatically created DSC compressed content will shorten the time needed for running the DSC compliance tests.

Please note, that the space needed for storing the full library **can be very large** (appr. 400 GBytes). Please make sure that the content will be stored in a medium that has the required space available.

### Misc. options

---

<i>Apply color conversions to saved images:</i>	When saving captured frames, the Color Mode selected in <i>Video</i> tab will be applied also to saved images.
<i>Bypass 4:2:x -&gt; 4:4:4 conversions:</i>	4:2:2 and 4:2:0 images are previewed and stored as received, without pixel doubling.
<i>Disable firmware version check:</i>	UCD Console lets the user operate a non-matching Software / Firmware combination. NOT RECOMMENDED.

---

### DPCD Decoder flags

Parameters for DPCD decoder in parsing AUX Channel transaction is DPCD Editor and Event Log.

---

<i>DETAILED_CAP_INFO_AVAILABLE:</i>	Information about DFP capability field in Sink DPCD register.
-------------------------------------	---

---

## Detaching and Cloning Tabs

Most of the UCD Console tabs can be detached into a separate window for monitoring and controlling separate features simultaneously. To detach a tab **Right-click** on a tab and select **Detach Window**. To glue the tab back to the main window, click on the red **Close** button in the top right-hand corner of the window or press **<Alt> + F4** on the keyboard.

Tabs can also be cloned (duplicated) in order to e.g., monitor various areas of DisplayPort DPCD or HDMI SCDC simultaneously without swapping addresses. To clone a tab **Right-click** on a tab and select **Clone Tab** or **Clone and Detach** to the two actions simultaneously.

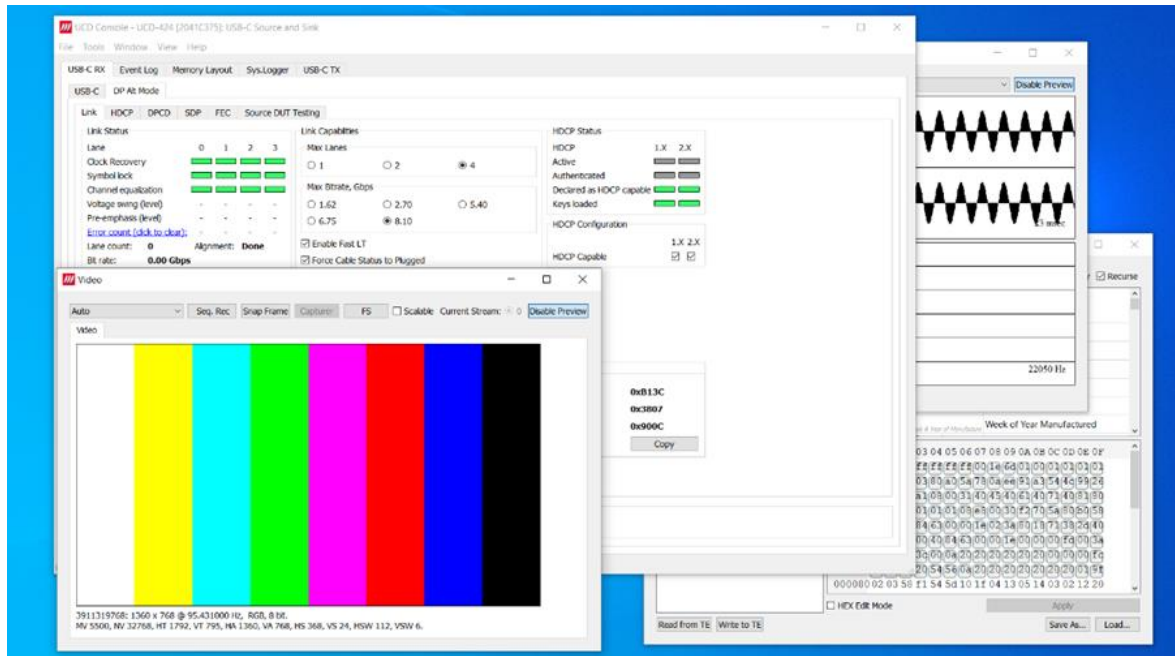

## 4. ANALYZER OPERATION

When used as an *Analyzer*, UCD-300 Series test equipment act as DisplayPort, HDMI or USB-C DisplayPort Alt Mode Sink or Receiver devices.

User is selecting device role when opening the Device when launching UCD Console. Selecting *DP Reference Sink*, *HDMI Reference Sink* or *DP Alt Mode Reference Sink*, UCD Console operates as Analyzer.

### Functionality Tabs

UCD Console features are presented in tabs. Standard tabs are similar in all functional roles, Interface Specific tabs present features and controls that are only available for a particular interface.

Some of the tabs are enabled by default, some only when an applicable license is included.

#### Standard Tabs

Analyzer role features six standard tabs:

- Video preview and saving (Video)
- Audio monitoring and saving (Audio)
- EDID editor (EDID)
- HDCP status monitor and control (HDCP)
- Source DUT Testing tab
- Event Log

#### Interface Specific Tabs

Based on the connected UCD device, additional interface specific tabs will be available.

##### [UCD-301, UCD-323 and UCD-340: DP and USB-C DP Alt Mode Reference Sink](#)

- Status information and control of the upstream link (Link)
- DPCD editor (DPCD)
- SDP sent by the Source device (SDP)

##### [UCD-301 and UCD-323: HDMI Reference Sink](#)

- Status information and control of the upstream link (Link)
- Received InfoFrame packets (InfoFrames).

##### [UCD-340: USB-C Reference Sink](#)

- USB-C Monitoring (USB-C)

---

**Note:** Some of the tabs are enabled by default, some only when an applicable license is included. Please refer to Appendix B Licensing of this document for description of features and licensing.

---

# Standard Tabs

## Video Tab

Video tab is the Preview window for the captured video frames.

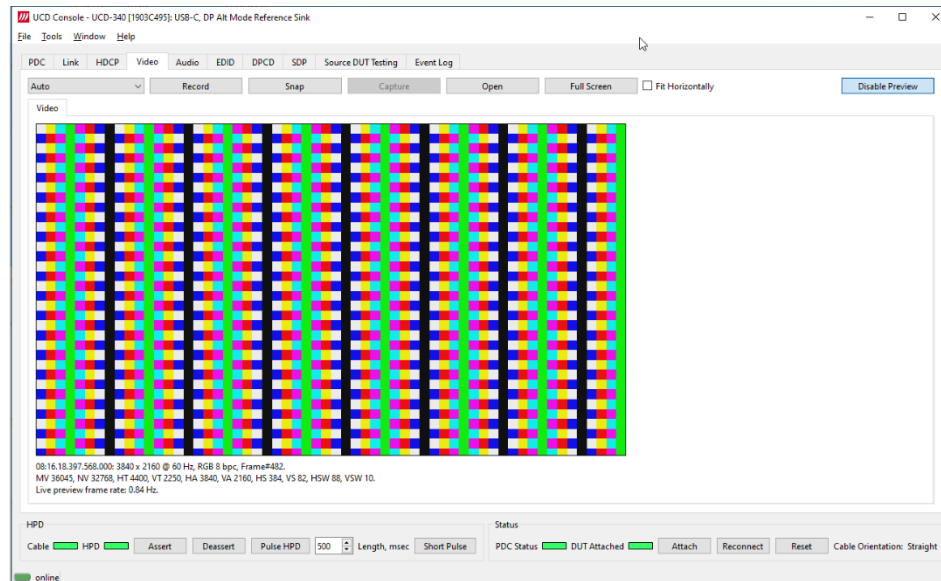

### Disable / Enable Preview

Click the button to start or stop capturing video frames.

### Video Status

The details of the captured video are presented below the preview window.



First row: Counter, frame size, frame rate, color mode, color depth, frame counter.

Second row: Mvid, Nvid, Horiz Total, Vert Total, Horiz Active, Vert Active, Horiz Start, Vert Start, Hor Sync Width, Vert Sync Width.

Third row: Live preview frame rate.

#### Note:

Please note that UCD test equipment are able to capture video at full frame rate.

*Live preview frame rate* indicates the rate of updating captured video on UCD Console preview screen. Live preview frame rate is limited e.g by the USB communication between UCD test equipment and the PC.

## Color Mode for preview

YCbCr SMPTE 170 -> RGB ▾

<i>No Conversion:</i>	The captured color components are mapped to R, G and B respectively. No color conversion will be done.
<i>Auto:</i>	The color mode is selected based on the information in the MSA. If there is no color information available, "No Conversion" is used.
<i>YCbCr (ITU-709) - &gt; RGB:</i>	The captured data components are interpreted as Y, Cb, and Cr respectively. Color conversion to RGB is done based on ITU-709 standard.
<i>SMPTE 170M - &gt; RGB:</i>	The captured data components are interpreted as Y, U, and V respectively. Color conversion to RGB is done based on SMPTE 170M standard.
<i>SMPTE ITU-601 - &gt; RGB:</i>	The captured data components are interpreted as Y, U, and V respectively. Color conversion to RGB is done based on ITU-601 standard.

**Note:** Please note that the color mode selection applies to the preview window only. All internal functions use the raw image data as captured from the input channel.

## Frame recording

Record

Clicking the button opens a dialog for definition of number of frames recorded. Buffered mode can also be enabled in this dialog.

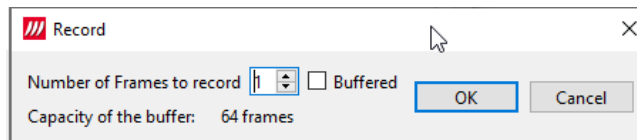

<i>Buffered</i>	When checked, all input frames are captured non-drop until the on-board frame buffer will be full. When not checked, only one input frame is buffered at a time. Frames will be skipped if the transfer of the data to the PC is slower than the input data rate.
<i>Capacity of the buffer</i>	Capacity of the on board frame buffer with the selected video mode.

**Note:** Please note that buffered mode cannot be used when Audio preview is enabled.

## Snap Frame

Snap

When clicked, one frame of the incoming video is captured and shown in a new tab. Each click captures a new frame and opens a new tab.

Color Information of the captured frame can be evaluated by placing the mouse cursor on top of the preview image.

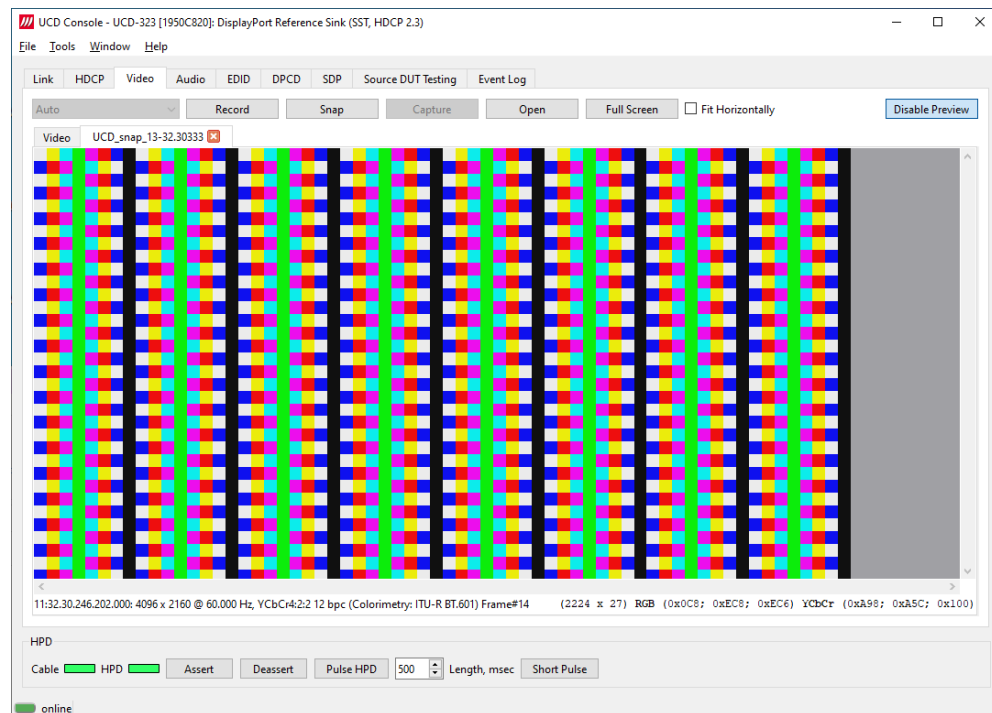

Info field in the lower right side of the bottom panel lists:

- Location of the cross cursor on the bitmap stating from the upper left corner
- The intensity of the color components of the pixel on the cursor location in HEX. Expressed as RGB and YCbCr.

## Zoom

Zoom level of the captured frame can be altered by right clicking on top of the preview image and selecting between

- Fit Window
- Zoom 25%
- Zoom 50%
- Zoom 100%
- Zoom 200%
- Zoom 500%

## Save Frame

The captured frame current tab can be saved to a bitmap file in the PC by right clicking on top of the preview image and selecting **Save as....** The format and storage location can be selected in the opening dialog. The available bitmap formats are BMP, JPG, PNG, and PPM.

---

### Note:

In PPM format the files are stored with the captured color depth, with other formats the color depth is truncated to 8 bits per color.

---

The selections in Tools > Options menu define if the frame bitmap will be stored as captured from the display interface or if the color mode conversion selected for preview will be applied.

## Buffered Capture (video, audio)

Capture of video, audio and metadata in a file for later analysis. Video can be stored as RGB or RAW data.

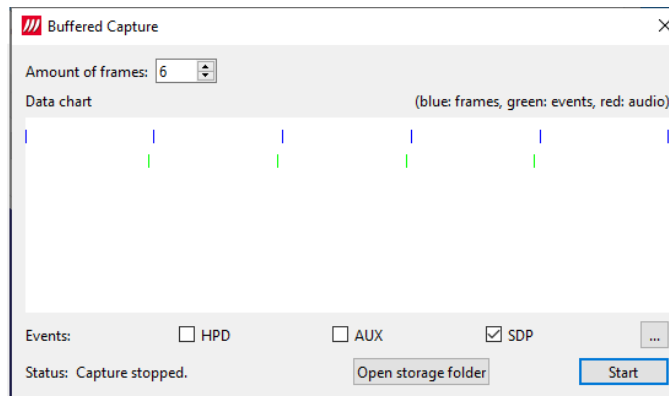

Data Chart indicates the approximate order of captured items with colored stripes (blue: video frames, green: events, red: audio data).

<i>Amount of frames</i>	The number of video frames captured.
<i>Events</i>	Please refer to chapter <i>Event Log</i> for details of the captured events
<i>Open storage folder</i>	Data save folder is defined in menu Tools > Options. Captured video, audio and data is saved in a subfolder of this folder. The name of the subfolder is "buffered_capture_yyyymmdd_hhmmss" (e.g., buffered_capture_20210301_130532).

---

**Note:** Video Preview needs to be disabled to use Data Capture functionality.

---



## Audio Tab

Audio tab has a preview of the audio signal format and the controls for audio playback and recording. Up to eight channels will be shown based on the received audio stream.

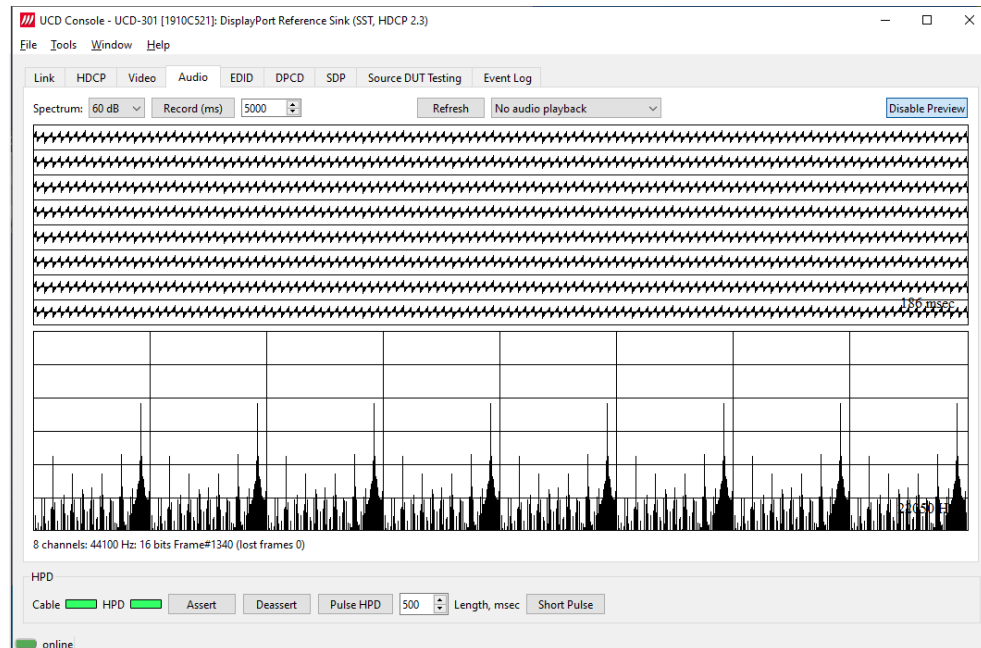

The audio signal format is shown in three ways

- The 'oscilloscope' panel displays the waveforms of the received audio channels.
- The frequency spectrum of the audio is shown in the lower panel. The range of the spectrum display is from 0 to 1/2 of the input sampling rate. The amplitude scale of the spectrum display can be selected between 'Linear' to 100 dB.

The span of the oscilloscope preview window is defined with **Playback buffer** found in Tools > Options dialog. The value is given in ksamples (1024 samples). The relation between the preview window span in milliseconds (msec) and the value given in *Playback buffer* depends on the sampling frequency. Please do not exceed the *Main buffer* set in the same dialog. Please refer to description of the *Video Audio and Misc Options* earlier in this document.

### Enable Preview / Disable Preview

This button controls capturing the audio data.

### Select Monitored Stream

When Multistreaming (MST) is enabled, the monitored stream can be selected from **Current Stream** selection in the bottom of the dialog.

---

#### Note:

Please note that if the captured audio signal is constant, and audio signal frequency and audio sampling rate (e.g. 1000 Hz audio and 32 KHz sampling) match audio preview sampling rate, the 'oscilloscope' panel will seem static. Signal capture can be verified by ensuring that Frame # below the panels is increasing.

---

## Playback device selection

The captured audio can be played back in the PC. The combo-box defines the audio device in the host PC through which the captured audio is played. By default, *No audio playback* is selected.

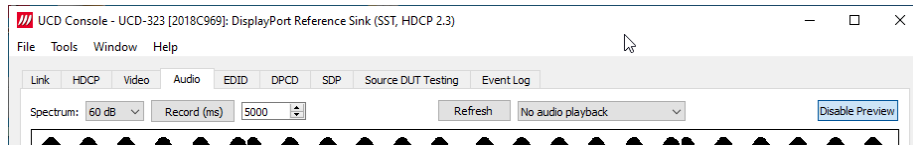

### Note:

Please note that the audio capabilities of the audio playback device of the PC are not automatically reflected in the audio capabilities description in UCD-300 EDID. Since UCD-300 is not performing any audio format conversion, it might occur that the source provides an audio format that the selected playback device is not supporting. In case a conflict occurs, please change manually the EDID content, or disable audio playback to monitor the waveforms in UCD Console.

## Refresh audio device list

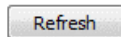

Click here to re-read the list of audio devices after making changes to the host PC configuration.

## Start audio recording

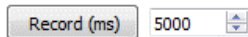

The captured audio can be recorded in the PC using Waveform Audio File Format, WAV (\*.wav) format. Recording duration is defined in milliseconds (ms). The folder where the audio file will be saved can be selected in Tools > Options.

## Input audio mode

2 channels: 44100 Hz: 16 bits Frame#413 (lost frames 0)

This field (in the bottom of the dialog) indicates detected audio mode in the input stream and the number of audio packets captured.

## EDID Tab

EDID Tab provides tools for accessing the EDID and Display ID of the UCD-300 Sink presented to the Upstream Source Device. There are three basic functions:

- Load and save EDID data files in the host PC
- Edit the EDID contents either in EDID Editor or in hex format
- Program and read the contents of the EDID memory of up to two virtual MST Ports (with UCD-323 special configuration)

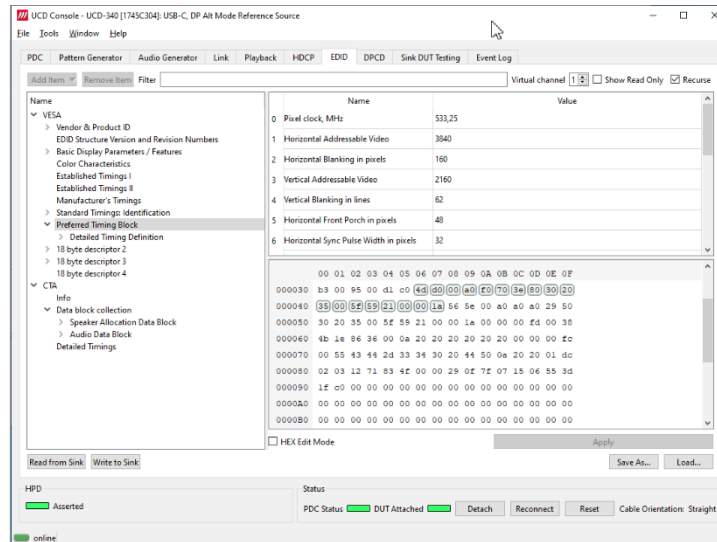

### EDID Files

With **Load...** and **Save as...** a hex EDID file can be read and written from the PC. Please note that the program does not alter the contents of the EDID file or verify its integrity during load and save operation.

---

**Note:** Four blocks (512 bytes) of EDID code is read. If the device is not supporting all four blocks, the non-supported area is replaced with blanks.

---

### EDID Editor

Please see the description of the EDID editor in Chapter [EDID Editor](#) later in this document.

## HDCP Tab

HDCP tab is the dialog for monitoring the HDCP (for *High-Bandwidth Digital Content Protection*) status and controlling the HDCP capabilities of the UCD-300 device.

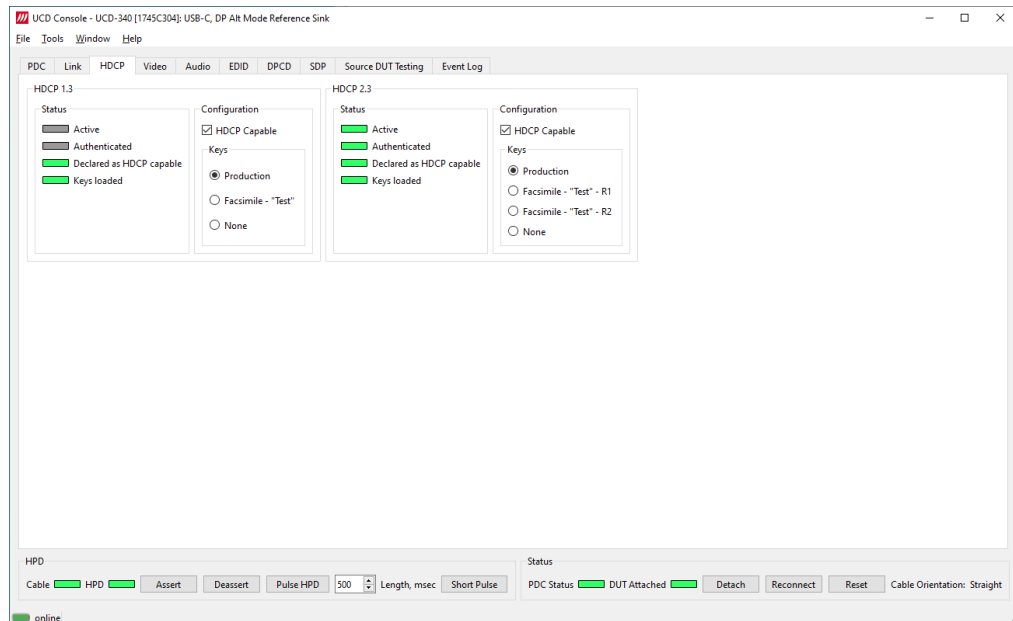

### Status

The status field indicates the HDCP status of the UCD device.

<i>Active:</i>	The link between UCD and the upstream source has been encrypted.
<i>Authenticated:</i>	The HDCP handshake between the UCD and the sink unit has been completed successfully.
<i>Declared as HDCP capable:</i>	The UCD unit recognizes HDCP handshake messages.
<i>Keys loaded:</i>	The HDCP keys are loaded to the UCD unit.

### Configuration

<i>HDCP Capable:</i>	To disable HDCP uncheck the box.
----------------------	----------------------------------

### Keys

Select between *Production* or *Facsimile* HDCP keys. To remove the keys, select *None*.

### HDCP 1.3 / 1.4 vs. HDCP 2.3

UCD-300 devices support by default HDCP 1.3 / 1.4 standard. The functionality for supporting HDCP 2.2 / 2.3 is enabled with HDCP 2.3 Support license

## Source DUT Testing Tab

Please refer to **Appendix E** later in this document for description of the tests available.

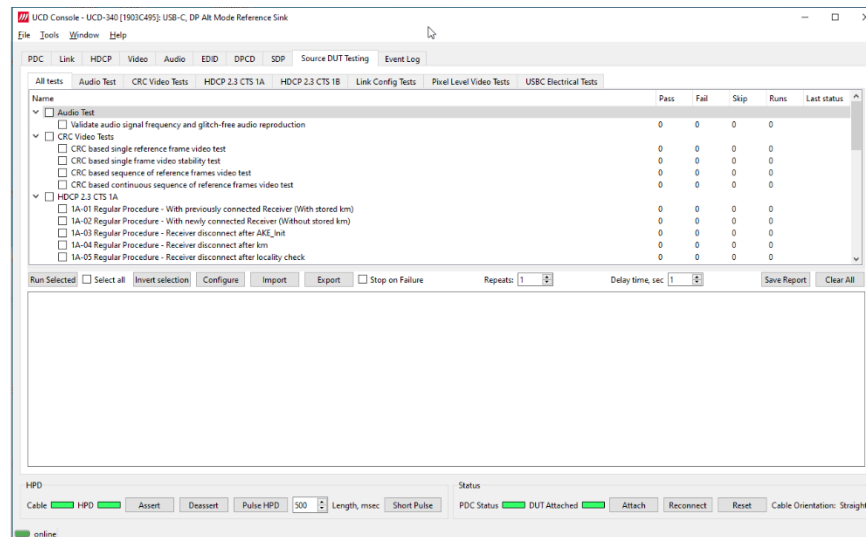

Select the tests for execution by clicking the corresponding row.

<b>Run Selected:</b>	Click to start selected tests. By clicking <i>Abort</i> the sequence is stopped.
<b>Select all:</b>	Select all tests in the selected tab.
<b>Invert selection:</b>	Invert selection of tests selected. Hint: To clear all selections, click <i>Select all</i> and then <i>Invert selection</i> .
<b>Configure:</b>	Clicking opens a dialog for defining the test time parameters for the selected test set. Please refer to <i>Test Parameters</i> below for details.
<b>Import:</b>	Load saved test parameter files (*.td or *.json).
<b>Export:</b>	Save test parameters for later use or for use in test automation. For saving parameters for later use in UCD Console, either format can be used. For saving parameters for TSI scripting, please use *.td files. For use with Python applications, please use *.json files.
<b>Stop on Failure:</b>	Stops execution of the selected tests if one of the tests fail
<b>Repeats:</b>	Repeat the selected test several times
<b>Delay time:</b>	Delay in seconds between individual tests.

At the completion of each test the result of the test is indicated in the matrix on the right hand side of the test panel. For each test the matrix lists the number of occurrences of each result and the number of tries performed.

<b>Save Report:</b>	Click to generate a HTML report file for sharing the results with other parties for viewing without UCD Console.
<b>Clear All:</b>	Clear the test log and the results matrix

## Test Parameters

Each test set has its dedicated set of test parameters. To open a dialog for defining the parameters click **Configure**.

Description of parameters for each test set can be found within the description of tests in Appendix E of this document.

## Saving Test Parameters

Test parameters can be saved in various ways.

- Export parameters in *Sink DUT Testing* tab to a \*.td file for later use in UCD Console or with TSI scripting or sharing.
- Export parameters in *Sink DUT Testing* tab to a \*.json file for later use in UCD Console or with Python applications or sharing.
- Save parameters in *Configure* dialog as Presets to be later used in Console. Please find a description below.

## Presets

In all parameter dialogs the selected parameters can be saved as Presets. Please click **Presets...** to save or recall a configuration.

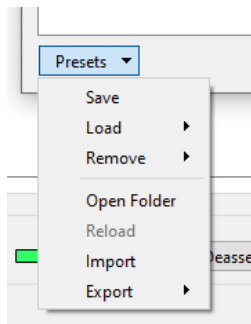

# DP and DP Alt Mode Reference Sink

Role:	Product:
DP Reference Sink (DP RX)	UCD-323, UCD-301
USB-C DP Alt Mode Reference Sink (DP RX)	UCD-340

When roles *DP Reference Sink* or *DP Alt Mode Reference Sink* are in use, the following interface specific tabs are available.

- Status information and control of the upstream link (Link)
- DPCD editor (DPCD)
- SDP sent by the Source device (SDP)

## DP Link Tab

Link tab shows the status and control items for the DisplayPort link.

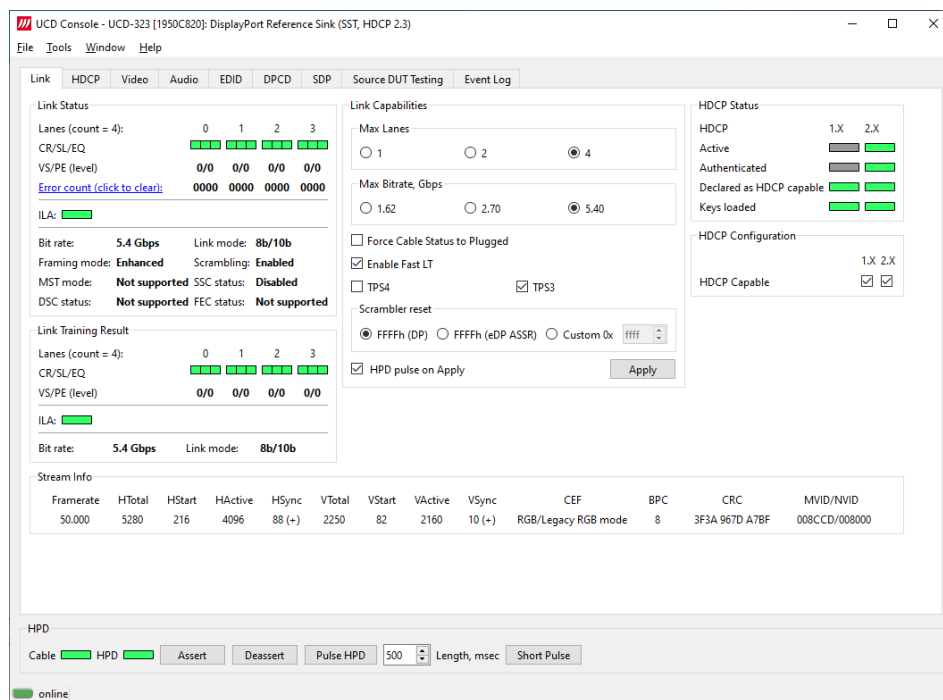

## Link Status

Link Status displays the status of the link training and the link parameters negotiated between UCD-300 Sink and the Upstream Source. It also lists status of other link modes. The data is retrieved from the DPCD status registers of the UCD-300 Sink. The status is updated automatically.

Link Status				
Lanes (count = 4):	0	1	2	3
CR/SL/EQ				
VS/PE (level)	0/0	0/0	0/0	0/0
<a href="#">Error count (click to clear):</a>	0000	0000	0000	0000
ILA:				
Bit rate:	5.4 Gbps		Link mode:	8/10
Framing mode:	Enhanced	Scrambling:	Enabled	
MST mode:	Not supported		SSC status:	Disabled
DSC status:	Not supported		FEC status:	Not supported

*Lanes:* Indicates the number of lanes used for DisplayPort or DisplayPort Alt Mode.

<i>Lanes:</i>	Indicates the number of lanes used for DisplayPort or DisplayPort Alt Mode.
<i>CR/SL/EQ:</i>	LED indicators for status of Clock Recovery / Symbol Lock / Channel Equalization for each of the four lanes
<i>VS/PE (level):</i>	Voltage Swing / Pre-emphasis level
<i>Error count:</i>	Content of DPCD Error Count registers
<i>ILA:</i>	LED indicator for 'Inter lane Alignment Done'
<i>Bit rate:</i>	Currently enabled link bit rate
<i>Link mode:</i>	Currently enabled channel coding (8b/10b or 128b/132b)
<i>Framing mode:</i>	Currently enabled Framing Mode (Normal or Enhanced)
<i>Scrambling:</i>	Status of link data scrambling (Enabled or Disabled)
<i>MST mode:</i>	Not Supported
<i>SSC Status:</i>	Status of Spread-Spectrum Clock (Enabled or Disabled)
<i>DSC Status:</i>	Not Supported
<i>FEC status:</i>	Not Supported

## Link Training Result

The result of the previous Link Training and values of some key parameters.

Link Training Result				
Lanes (count = 4):	0	1	2	3
CR/SL/EQ				
VS/PE (level)	0/0	0/0	0/0	0/0
ILA:				
Bit rate:	5.4 Gbps		Link mode:	8/10



## Link Capabilities

Link capabilities allows the user to change the way the Sink capabilities are announced in the DPCD capability registers of the UCD-300 Sink. Maximum Lane Count and Maximum Link Rate are set with their corresponding radio buttons.

**Link Capabilities**

Max Lanes

1     2     4

---

Max Bitrate, Gbps

1.62     2.70     5.40

---

Force Cable Status to Plugged

Enable Fast LT

TPS4                       TPS3

---

Scrambler reset

FFFFh (DP)     FFFFh (eDP ASSR)     Custom 0x

---

HPD pulse on Apply

<i>Force cable status to plugged:</i>	When checked, sink functionality is active regardless of a failure of upstream device detection e.g., due to incorrect AUX Channel electrical termination.
<i>Enable Fast LT:</i>	Indicates support for link training without AUX transactions.
<i>TPS4, TPS3:</i>	Indicate support for Link Training Pattern Sequence 4 and 3 correspondingly.
<i>Scrambler Reset:</i>	Selection of the value to which the Linear Feedback Shift Register (LFSR) is reset during scrambler reset
<i>HPD pulse on Apply:</i>	Select to apply a Hot-Plug Detect (HPD) pulse automatically after updating the status. HPD pulse duration will be defined in the <i>Pulse HPD</i> field in <i>HPD</i> dialog in the bottom of the tab.

To update the new status to the DPCD registers click **Apply**.

## HDCP Status

Copy of the status from HDCP Tab. Please refer to chapter *HDCP Tab* later in this document for detailed description.

**HDCP Status**

	1.X	2.X
Active	<input type="checkbox"/>	<input checked="" type="checkbox"/>
Authenticated	<input type="checkbox"/>	<input checked="" type="checkbox"/>
Declared as HDCP capable	<input checked="" type="checkbox"/>	<input checked="" type="checkbox"/>
Keys loaded	<input checked="" type="checkbox"/>	<input checked="" type="checkbox"/>

---

**HDCP Configuration**

	1.X	2.X
HDCP Capable	<input checked="" type="checkbox"/>	<input checked="" type="checkbox"/>

## HDCP Configuration

Enable and disable HDCP 1.3 or HDCP 2.3 capability of UCD Sink. Duplicates of the controls found in HDCP tab.

## Stream Info

Video Stream Info are retrieved from the Main-Stream Attributes (MSA) of the monitored stream. Frame rate is measured by UCD Local Sink.

Stream Info												
Framerate	HTotal	HStart	HActive	HSync	VTotat	VStart	VActive	VSync	CEF	BPC	CRC	MVID/NVID
50.000	5280	216	4096	88 (+)	2250	82	2160	10 (+)	RGB/Legacy RGB mode	8	3F3A 967D A7BF	008CCD/008000

The content of *Stream Info* table can be copied by right-clicking on the table and selecting **Copy**.

<i>Framerate</i>	Vertical refresh rate
<i>HTotal</i>	Horizontal total of transmitted main video stream, measured in pixel count.
<i>HStart</i>	Horizontal active start from leading edge of HSync, measured in pixel count.
<i>HActive</i>	Horizontal active, number of active pixels in video line
<i>HSync</i>	HSync width, measured in pixel count.
<i>VTotat</i>	Vertical total of transmitted main video stream, measured in line count.
<i>VStart</i>	Vertical active start from leading edge of VSync, measured in line count.
<i>VActive</i>	Vertical active, number of active lines in video frame
<i>VSync</i>	VSync width, measured in line count.
<i>CEF</i>	Used color mode: Color format + subsampling / colorimetry
<i>BPC</i>	Color depth in bits per color (BPC)
<i>CRC</i>	16-bit Cyclic redundancy check (CRC) value per color component calculated from active pixels
<i>MVID/NVID</i>	Mvid and Nvid video time stamp values

**Note:** Please note that the MSA information used for Video Timing Details is provided by the Upstream Source, it is not measured by the UCD Local Sink.

## HPD

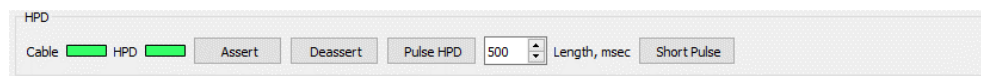

<i>Cable:</i>	LED indicates that the hardware has detected an upstream cable.
<i>HPD:</i>	LED indicates that the HPD signal is Asserted (logical “high”).
<i>Deassert:</i>	Click button to set HPD line to logical “low” (de-asserted) and hence no HPD pulse can be generated.
<i>Assert:</i>	Click to re-activate the HPD line (set to logical “high”).
<i>Pulse HPD:</i>	Click to apply an HPD Pulse with programmable duration. Duration will be defined in the provided field.
<i>Short Pulse:</i>	Click to apply a short pulse. Pulse duration is 1 ms.

## DPCD Tab

DPCD tab is a tool for monitoring and editing the DPCD registers of the DP Sink.

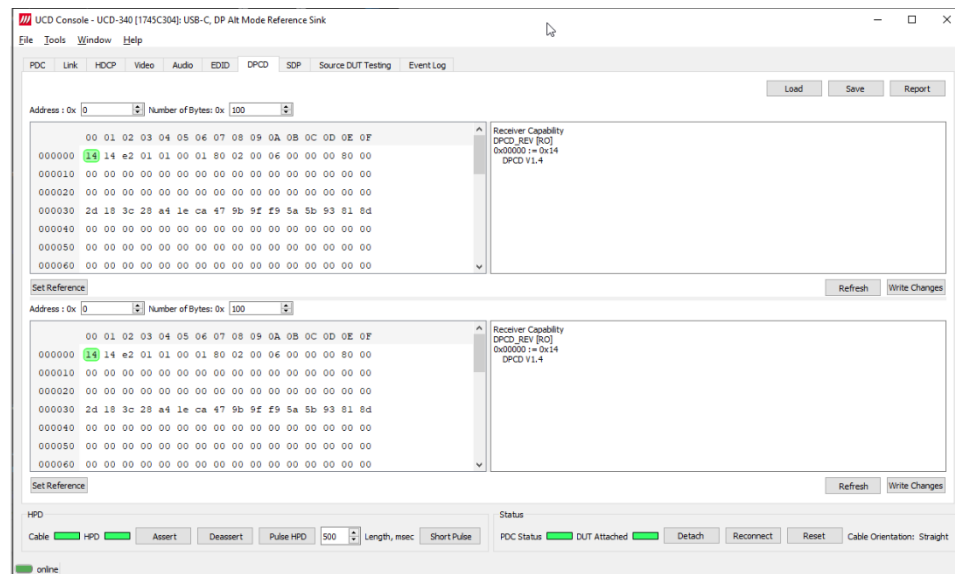

The *DPCD Decoder* panels on the right show the interpretation of the DPCD byte selected on the monitoring windows. The selected byte is shown with a green background.

*DPCD Decoder* flags in Tools > Options contain control of DETAILED\_CAP\_INFO\_AVAILABLE flag.

<i>Refresh:</i>	Re-read the data from the DPCD registers to the window in question
<i>Write Changes:</i>	Write the portion of data shown in the window in question to the DPCD registers.
<i>Set Reference:</i>	Store currently shown data as a reference for comparison

When the data is *Refreshed* from the DPCD registers the changed bytes will be highlighted with **blue** color.

The fields edited by the user will be highlighted with **red** color.

### Saving and Loading DPCD Content

DPCD data in the selected address areas can be saved as a file in your PC. There are two alternative formats listed below. Please select the format when saving:

- Binary *DPCD Fata File* format (\*.DPD). This is Unigraf proprietary format. You can also load the DPCD content stored in this format.
- *HEX Dump* (\*.HEX) in a human readable text format.

*Save:* Store DPCD content to a file.

*Load:* Recall DPCD data saved in DPCD Data File (\*.DPD) format to the editor.

## SDP Tab

In SDP Tab shows the *Secondary-Data Packets* sent by the Source device. Click **Refresh** to re-read the data.

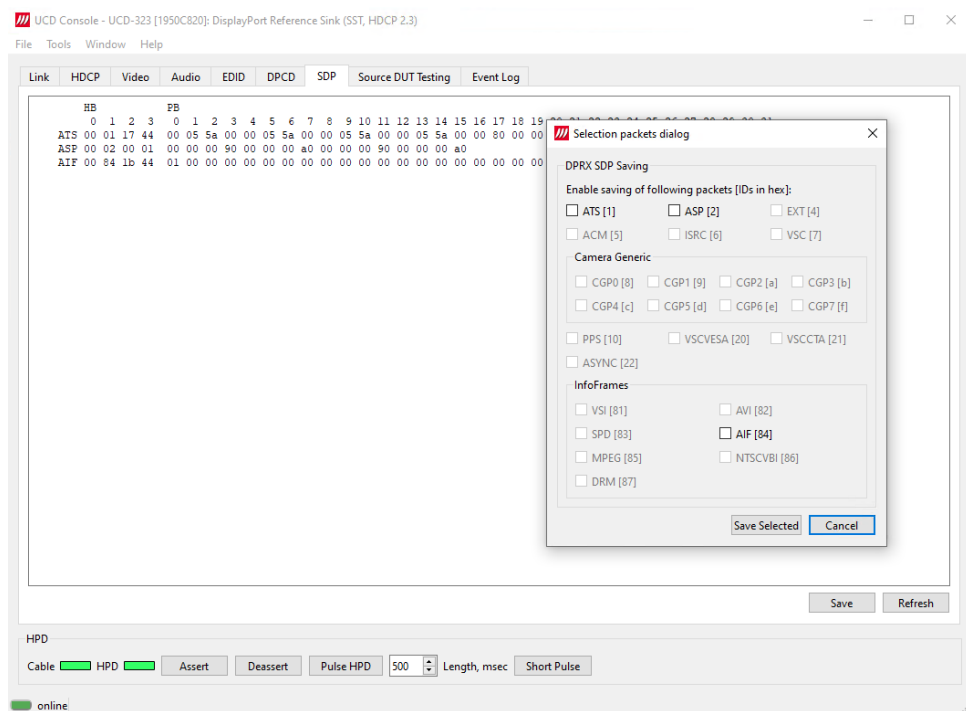

The following packets are recognized:

- Audio\_TimeStamp
- Audio\_Stream
- Extension
- Audio\_CopyManagement
- ISRC (International Standard Recording Code)
- Video Stream Configuration (VSC)
- Camera Generic 0
- Camera Generic 1
- Camera Generic 2
- Camera Generic 3
- Camera Generic 4
- Camera Generic 5
- Camera Generic 6
- Camera Generic 7
- Vendor-Specific Infoframe packet
- AVI InfoFrame packet
- Source Product Descriptor InfoFrame packet
- Audio InfoFrame packet
- MPEG Source InfoFrame packet
- Dynamic Range and Mastering InfoFrame
- Picture Parameter Set (PPS)

### Saving SDP Packets

Packets can be saved in a file in binary format. Click *Save* and in the dialog select the packet types of choice. File name will be of format *ATS\_2022-07-28T15\_54\_24.bin*, where *ATS* is the packet type and *2022-07-28T15\_54\_24* the time stamp.

Saved packets can be evaluated and edited using *Packet Editor*. Please see section *Packet Editor* later in this document

# HDMI Reference Sink

Role:	Product:
HDMI Reference Sink (HDMI RX)	UCD-301, UCD-323

When *HDMI Reference Sink* role is in use, the following interface specific tabs are available.

- Status information and control of the upstream link (Link)
- Received InfoFrame packets (InfoFrames).

## HDMI Link Tab

Link tab contains four panels: Behavior, Status, TMDS Status, FRL Capabilities, FRL Status, Audio Return Channel, HDCP Status and Configuration, Video Status and HPD.

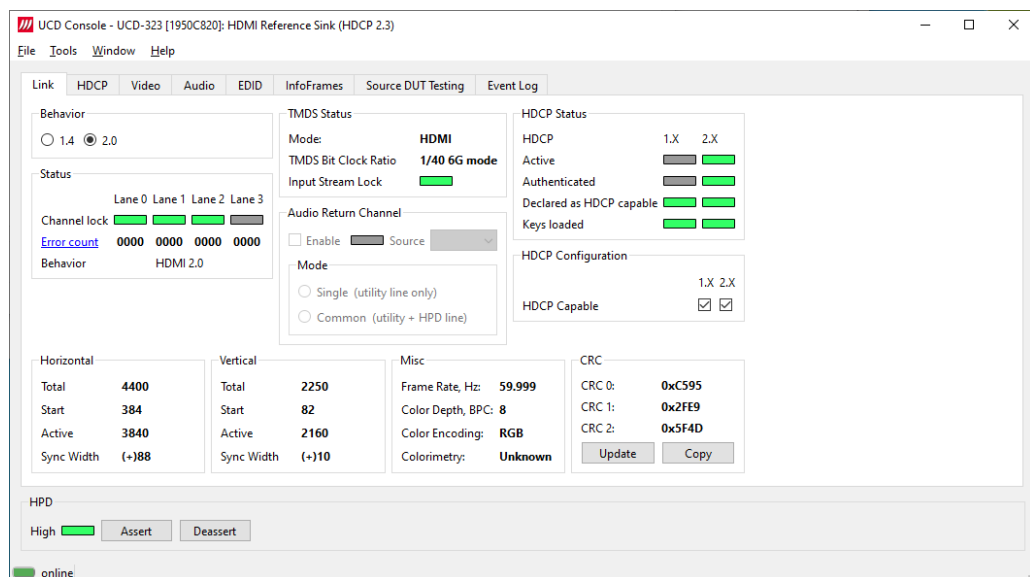

### Behavior

Selection of HDMI operation mode: HDMI 1.4 or HDMI 2.0 Please perform HPD **Deassert -Assert** after change of mode.

### Status

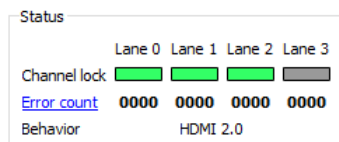

<i>Channel lock</i>	Indication of channel lock status in TMDs links 0 to 2
<i>Error count</i>	Status of SCDC Error Count Registers
<i>Behavior</i>	HDMI operation mode (HDMI 1.4 or HDMI 2.0)

## TMDS Status

TMDS Status	
Mode:	<b>HDMI</b>
TMDS Bit Clock Ratio	<b>1/40 6G mode</b>
Input Stream Lock	

*Mode:* Indication of HDMI / DVI mode

*TMDS Bit Clock Ratio:* TMDS Bit Period / TMDS Clock Period ratio (1/10 or 1/40)

*Input Stream Lock:* Indication of TMDS character lock

## Audio Return Channel (UCD-301)

Audio Return Channel	
<input checked="" type="checkbox"/> Enable	 Source <b>HDMI Loopback</b> ▾
Mode	
<input checked="" type="radio"/> Single (utility line only) <input type="radio"/> Common (utility + HPD line)	









*Enable:* Select to enable eARC function.

*Source:* Select the eARC audio Source to be either  
 - Loopback of captured HDMI audio, or  
 - Audio received in the S/PDIF input

*Mode:* Select eARC mode

## HDCP Status

Copy of the status from HDCP Tab. Please refer to chapter *HDCP Tab* later in this document for detailed description.

HDCP Status		
HDCP	1.X	2.X
Active		
Authenticated		
Declared as HDCP capable		
Keys loaded		

HDCP Configuration	
	1.X 2.X
HDCP Capable	<input checked="" type="checkbox"/> <input checked="" type="checkbox"/>

## HDCP Configuration

Enable and disable HDCP 1.3 or HDCP 2.3 capability of UCD Sink. Duplicates of the controls found in HDCP tab.

## Video Mode

Timing and color mode details of the video as retrieved from stream metadata. Frame rate is measured by UCD Local Sink.

Horizontal		Vertical		Misc		CRC	
Total	<b>4400</b>	Total	<b>2250</b>	Frame Rate, Hz:	<b>59.999</b>	CRC 0:	<b>0xC595</b>
Start	<b>384</b>	Start	<b>82</b>	Color Depth, BPC:	<b>8</b>	CRC 1:	<b>0x2FE9</b>
Active	<b>3840</b>	Active	<b>2160</b>	Color Encoding:	<b>RGB</b>	CRC 2:	<b>0x5F4D</b>
Sync Width	<b>(+)88</b>	Sync Width	<b>(+)10</b>	Colorimetry:	<b>Unknown</b>	<input type="button" value="Update"/> <input type="button" value="Copy"/>	

## CRC

The 16-bit **CRC** (checksum, cyclic redundancy check) values of the three color components calculated by the Sink hardware. To re-calculate, click **Update**. Click **Copy** to store the information in Windows clipboard.

## HPD

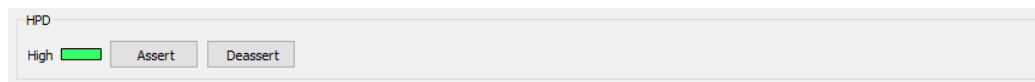

<i>HPD LED:</i>	Indicates that the HPD signal is Asserted (logical "high").
<i>Assert:</i>	Click to re-activate the HPD line (set to logical "high").
<i>Deassert:</i>	Click button to set HPD line to logical "low" (de-asserted) and hence no HPD pulse can be generated.

## InfoFrame Tab

InfoFrame Tab is enabled with *UCD Pro for HDMI Sink* license. Please click **Update** to re-read the InfoFrame data.

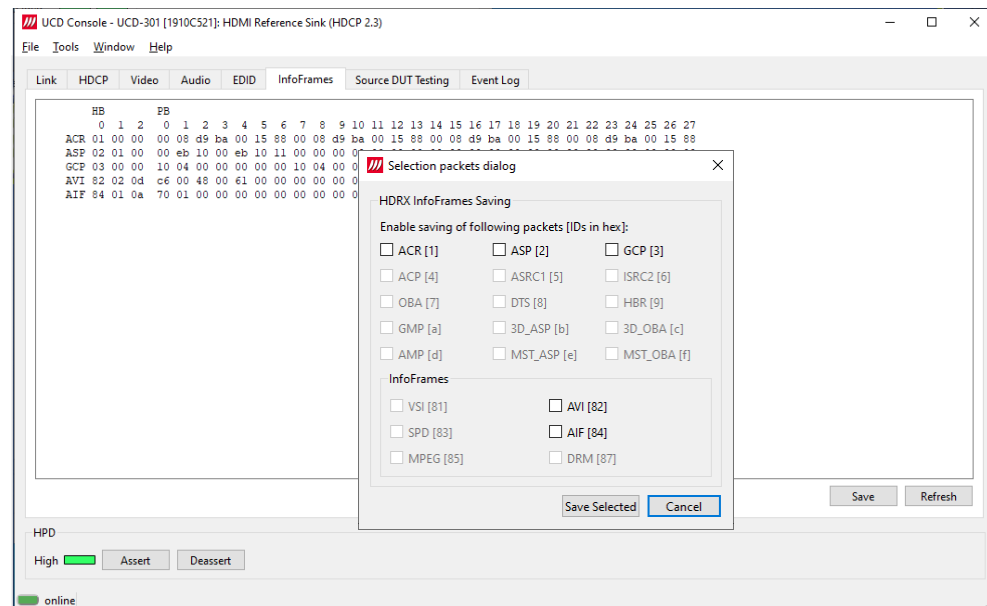

The following received inframes are shown:

- ACR (Audio Clock Regeneration)
- ASP (Audio Sample Packet)
- GCP (General Control Packet)
- ACP (Audio Content Protection Packet)
- ISRC1 (International Standard Recording Code)
- ISRC2 (International Standard Recording Code)
- OBA (One Bit Audio sample packet)
- DTS (DTS Audio packet)
- HBR (High Bitrate Audio stream packet)
- GMP (Gamut Metadata packet)
- 3D ASP (3D Audio Sample packet)
- 3D OBA (3D One Bit Audio sample packet)
- AMP (Audio Metadata Packet)
- MST\_ASP (Multi-stream audio sample packet)
- MST\_OBA (One Bit Multi-stream audio sample packet)
- VSI (Vendor Specific InfoFrame)
- AVI (Auxiliary Video Information)
- SPD (Source Product Descriptor)
- AIF (Audio InfoFrame)
- MPEG (MPEG Source InfoFrame)
- DRM (Dynamic Range and Mastering InfoFrame)

### Saving Infoframes

Infoframe packets can be saved in a file in binary format. Click *Save* and in the dialog select the packet types of choice. File name will be of format *EMP\_2022-07-28T15\_54\_24.bin*, where *EMP* is the packet type and *2022-07-28T15\_54\_24* the time stamp.

Saved packets can be evaluated and edited using *Packet Editor*. Please see section *Packet Editor* later in this document



## USB-C Monitoring

Role:	Product:
DP Alt Mode Reference Sink	UCD-340

When UCD-340 is used in *DP Alt Mode Reference Sink* role, *USB-C Power Delivery* tab is available. Similar USB-C Power Delivery tab is available also when UCD-340 is used in *DP Alt Mode Reference Source* role.

### USB-C Power Delivery Tab (PDC)

In *USB-C Power Delivery* tab (PDC) operator can evaluate the status of the USB-C connection and USB Power Delivery Contract, the various roles adopted, and the configuration of the DP Alternate Mode. The user can set the initial roles for the UCD-340 test equipment and the optional capabilities for UCD-340 in the PD Contract.

Controls allow user also to swap roles and e.g., use the Cable Swap feature of Unigraf Electrical Test cable.

*USB-C Power Delivery* tab contains a *Status* panel and four horizontal tabs for monitoring and configuring the USB Power Delivery Protocol related features of UCD-340.

- Capabilities
- Power Source
- Power Sink
- External Power Load
- DP Alt Mode
- Cable Info
- Controls

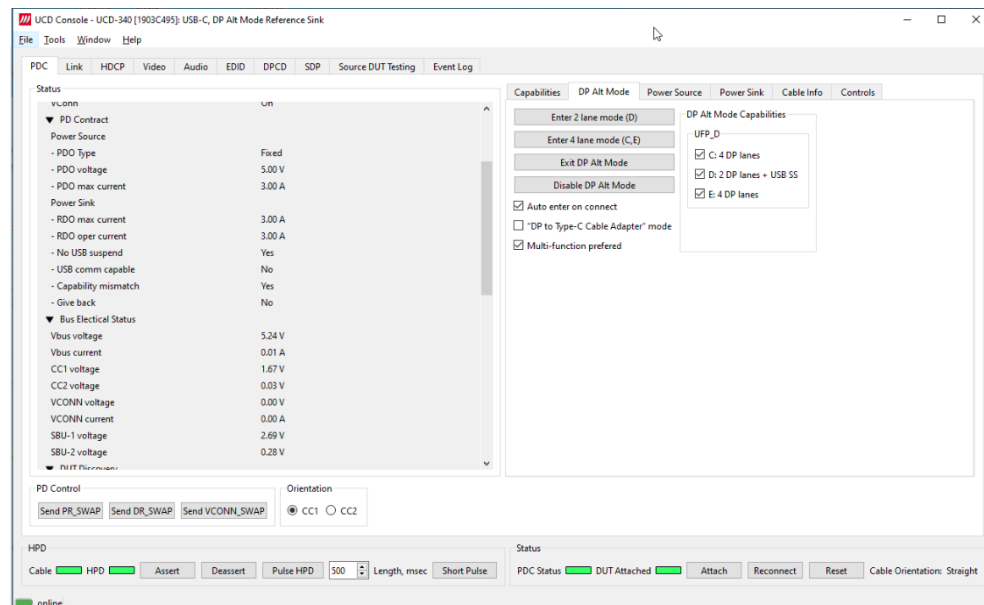

## Status List

In Status List the information is presented in foldable sections. Each section contains information related to one feature of USB-C interface or PD protocol. The user can fold out the sections needed for the task in question.

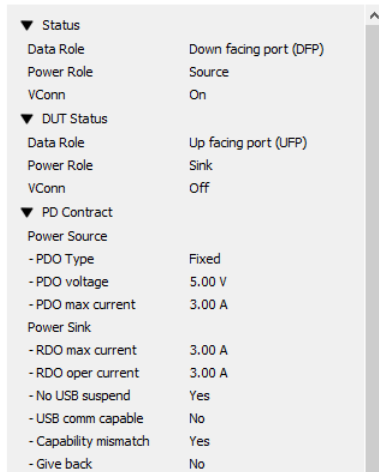

<i>Status:</i>	UCD-340 internal status (Data role, Power Role, VConn status)
<i>DUT Status:</i>	Status of the connected USB-C port partner gained from status messages (Data role, Power Role, VConn status)
<i>PD Contract:</i>	Details of the PD Contract (Power Source: PDO Type, PDO Voltage, PDO max current; Power Sink: RDO max current, RDO operating current, USB statuses)

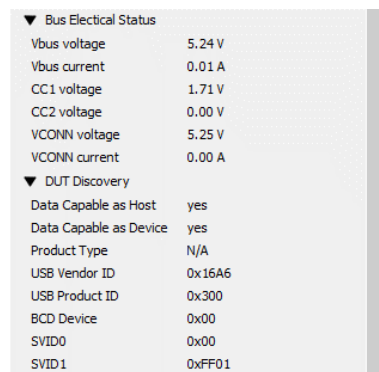

<i>Bus Electrical Status:</i>	Vbus voltage and current, CCI and CC2 voltage, VCONN voltage and current)
<i>DUT Discovery:</i>	Status of the connected USB-C port partner gained from discovery messages (Data Capabilities, Product Type, Vendor and Product ID, device version number, supported SVIDs)

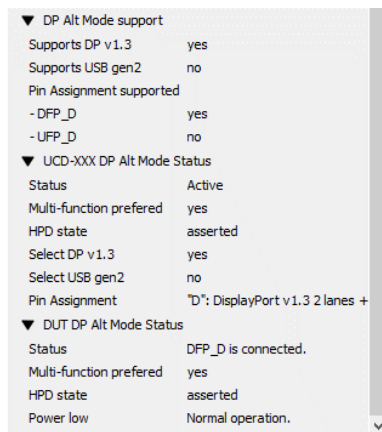

<b>DP Alt Mode support:</b>	Supported DisplayPort Alt Mode features (Support DP v 1.3, Support USB gen2, Pin assignments supported as DFP_D and UFP_D)
<b>TE Alt Mode Status:</b>	UCD internal DP Alternate mode status (DP Alt Mode Status, Multi-function preferred, HPD status, Select DP 1.3, USB gen2 and Pin Assignment selected)
<b>DUT Alt Mode Status:</b>	Status of the connected USB-C port partner gained from status update messages (DP Alt Mode Status, Multi-function preferred, HPD State, Power low)

## Capabilities

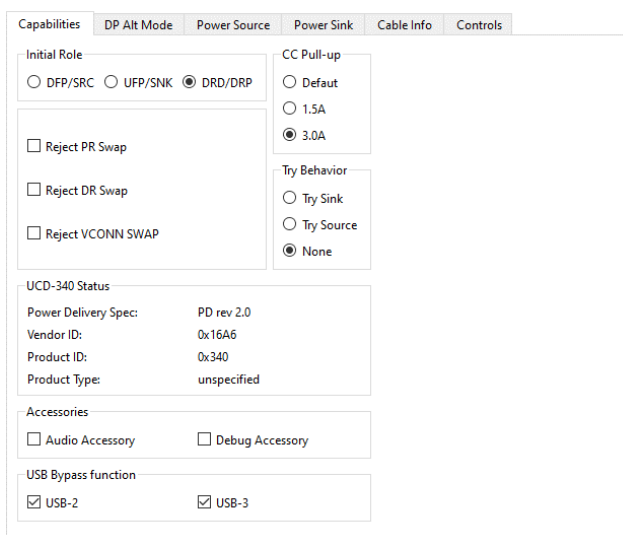

<b>Initial Role:</b>	Defines the role which UCD-340 presents itself in the start PD communication (both power and data role).
<b>Reject Swaps:</b>	Allow or reject mode swap requests from the connected port partner.
<b>CC Pull-up:</b>	Control of Rp that Source uses to advertise the initial current source capability using USB-C Current method.
<b>Try Behavior:</b>	Control the USB-C PD role that UCD-340 initially takes in the connection handshake.
<b>UCD-340 Status:</b>	Status information provided by UCD-340.

## Accessories

Accessories	
<input type="checkbox"/> Audio Accessory	<input type="checkbox"/> Debug Accessory
USB Bypass function	
<input checked="" type="checkbox"/> USB-2	<input checked="" type="checkbox"/> USB-3

---

*Audio Accessory:* Enable simulation of Audio Accessory support

---

*Debug Accessory:* Enable simulation of Debug Accessory support

---

Enabling *Audio Accessory* and *Debug Accessory* extends USB Type-C Connection State Machine with \*.Accessory states. (Please refer to USB Type-C specification for details).

---

**Note:** Please note that UCD-340 does not support any physical connections for the Accessory functions. The selections enable only behavioral simulation.

---

### USB-2 Bypass Function

Control of data bypass between USB-C connector and USB A and B connectors. Please refer to chapter *UCD-340 > Functional Description* earlier in this manual.

---

*USB-2:* Enable USB-2 data bypass

---

*USB-3:* Enable USB-3 data bypass

---

## DP Alt Mode

Controls and capability settings for DisplayPort Alternate Mode.

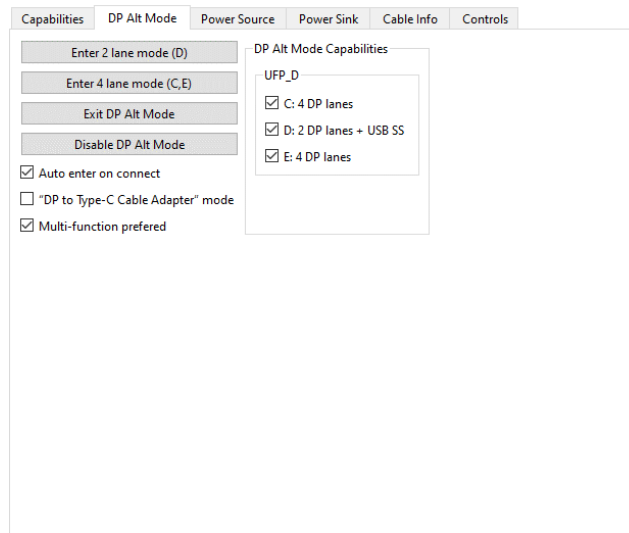

<i>Enter 2 lane mode (D):</i>	Restart mode discovery and advertise support for mode D (2 DP lanes + USB SS).
<i>Enter 2 lane mode (C,E):</i>	Restart mode discovery and advertise support for modes C and D (4 DP lanes).
<i>Exit DP Alt Mode:</i>	Exit DP Alternate mode.
<i>Disable DP Alt Mode:</i>	Exit DP Alternate mode and advertise no DP Alternate mode support.
<i>Auto enter on connect:</i>	Start mode discovery after connection and enter DP Alternate mode if suitable configuration is found.
<i>“DP to Type-C Cable Adapter” mode:</i>	Perform an automated procedure for connecting a DP to USB-C bidirectional cable. Please find an abstract of the issue below.
<i>Multi-function preferred:</i>	When entering DP Alternate Mode, select mode D.

### DP to Type-C Cable Adapter

*USB-C to DP Bi-directional Cable contains an active converter microchip that needs to be powered from USB-C interface. Therefore UCD-340 must be initially configured in power source role for USB Default Operation where it applies vSafe5V on Vbus to power up the microchip in the cable.*

*USB-C to DP Bi-directional Cable uses pin assignment E when acting as a source. In order to provide the “cable” a possibility to request the configuration it needs, UCD-340 has to initiate a Data Role Swap to be in UFP, Device, data mode.*

### DP Alt Mode Capabilities

Supported Pin Assignments declared in DisplayPort Capabilities discover message. Separate for UFP\_D (DisplayPort sink) and DFP\_D (DisplayPort source)

## Power Source

Definition of Power Data Objects (PDO) for UCD-340 when acting as *Power Source Port*.

The assigned Vbus voltage level to each PDO is limited according to the following table:

	5 V	9 V	12 V	15 V	20 V
PD01	•				
PD02		•			
PD03			•		
PD04				•	
PD05 to PD07					•

*PDO Type*: Definition of power source type (Disabled, Fixed, Variable or Battery)

<i>Refresh</i>	Re-read status from UCD-340
<i>Apply</i>	Program new values to UCD-340
<i>Send PDO</i>	Send a Source Capabilities message
<i>Load PDO</i>	Load a stored Power Source PDO configuration from file.
<i>Save PDO</i>	Store current Power Source PDO configuration to a file

---

**Note:** The requirement is that Sources shall supply at least one fixed supply capable of supplying vSafe5V

---

**Note:** Please note that UCD-340 is not able to simulate as Source the electrical behavior of Variable and Battery source types.

---

**Note:** Please note that External USB-C Power Test Unit is needed to supply 9 V, 15 V and 20 V Vbus voltages.

---

## Power Sink

Definition of Power Data Objects (PDO) for UCD-340 when acting as *Power Sink Port*.

The screenshot shows the 'Power Sink' configuration window. It includes tabs for 'Capabilities', 'DP Alt Mode', 'Power Source', 'Power Sink', 'Cable Info', and 'Controls'. The 'Power Sink' tab is active, showing configuration for four PDOs (PDO1 to PDO4). PDO1 is 'Mandatory', PDO2 is 'Battery', PDO3 is 'Variable', and PDO4 is 'Disabled'. Parameters for each PDO include Oper Current (mA), Voltage (mV), Max Power (mW), Max Voltage (mV), and Min Voltage (mV). Below this are controls for 'PD Contracts selection override' (with an 'Enable' checkbox and 'Index' dropdown), 'PDO type priority' (with a dropdown set to 'Prefer higher voltage'), and buttons for 'Refresh', 'Apply', 'Load PDO', and 'Save PDO'. At the bottom is the 'Vbus Load Control' section, featuring two sliders: 'Internal' and 'External'. Each slider has a 'High' position and a table of resistance values in Ohms (approximate).

Category	High	10 (x.x)	5.5 (x.x)	3.55 (x.x)	3.5 (x.x)	2.6 (x.x)	2.14 (x.x)	1.76 (x.x)	Ohm A (approx.)	
Internal										
External		13.9 (x.x)	10.6 (x.x)	9.1 (x.x)	7.6 (x.x)	6.6 (x.x)	5.6 (x.x)	4.6 (x.x)	3.6 (x.x)	1.8 (x.x)

*PDO Type*: Definition of power source type (Disabled, Fixed, Variable or Battery)

**Note:**

Please note that UCD-340 is not able to simulate as Sink the true electrical behavior needed for Variable and Battery source types.

<i>PD Contract selection override</i>	Enable: Override the PDO selection made in PD automatic handshake. Index: Override selection of PDOs advertised by Source Device.
<i>PDO type priority</i>	Setting of the policy used for automatic selection from available PDOs advertised by Source Device. (Prefer higher current / Prefer higher voltage / Prefer higher power)
<i>Refresh</i>	Re-read status from UCD-340
<i>Apply</i>	Program new values to UCD-340
<i>Load PDO</i>	Load a stored Power Source PDO configuration from file.
<i>Save PDO</i>	Store current Power Source PDO configuration to a file

### Vbus Load Control

Control of the load resistances affecting the current that UCD-340 sinks from Vbus. The *Internal* load resistances are used when External USB-C Power Test Unit is not present. When External USB-C Power Test Unit is connected to UCD-340 *External* resistors will be used.

Please see UCD-340 Vbus voltage source capability in the table below. Without *Unigraf External USB-C Power Test Unit* UCD-340 is able to source only 5 V.

Vbus power source capability	5 V				9 V	12 V	15 V	20 V
	0.5 A	0.9 A	1.5 A	3 A	3 A	3 A	3 A	5 A
UCD-340	•	•	•	•				
UCD-340 with Eternal Power Test Unit	•	•	•	•	•	•	•	•

**Warning:**

When using Unigraf External USB-C Power Test Unit, please make sure that the attached USB-C connection cable is qualified for the current ratings used.

Using a cable that is not qualified for high current will potentially lead to overheating and severe damage.

## Cable Info

Cable Info tab displays the information received from the cable as a response to *Discover Identity* command sent to SOP'.

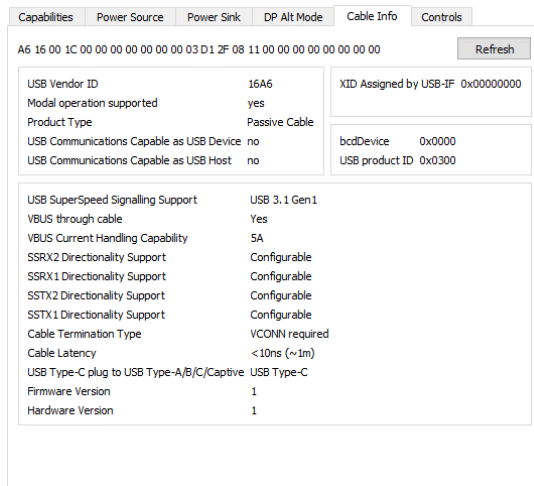

## Controls

Control tab includes miscellaneous controls related to UCD-340 behavior as a USB-C PD Port Partner.

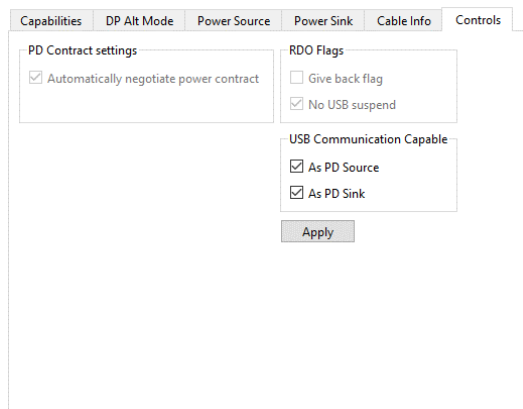

### PD Contract Settings

*Automatically negotiate power contract:* When selected UCD-340 will start power contract negotiation if suitable configuration is found.

### RDO Flags

*Give back flag:* When selected, UCD-340 sets *GiveBack* flag in its *Request Data Object*

*No USB suspend:* When selected, UCD-340 sets *No USB Suspend* flag in its *Request Data Object*

### USB Communication Capable

You can control the *USB Communication Capable* bit in its *Request Data Object*.



## Bottom Panel

Bottom panel includes statuses and controls for the USB-C connection

### PD Control

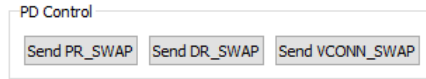

<i>Send PR_SWAP:</i>	Send <i>PR_Swap</i> message to request an exchange of power roles.
<i>Send DR_SWAP:</i>	Send <i>DR_Swap</i> message to request an exchange DFP and UFP operation between Port Partners while maintaining the direction of power flow over Vbus.
<i>Send VCONN_SWAP:</i>	Send <i>VCONN_Swap</i> message to request an exchange of Vconn Source.

### Status

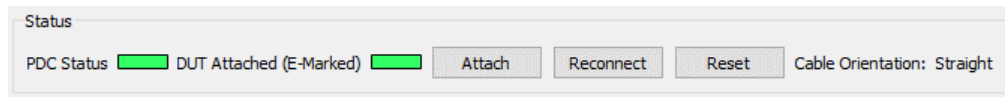

<i>PDC Status</i>	LED for USB-C Power Delivery Control
<i>DUT Attached:</i>	Indication that " <i>Attach</i> " is detected by the Source port in one of its CC lines.
<i>Detach:</i>	Manually <i>Detach</i> USB-C port partners.
<i>Reconnect:</i>	Restart USB-C Source-to-Sink attach procedure.
<i>Reset:</i>	Reset the PD Controller in UCD-424 to overcome abnormal situations.
<i>Cable Orientation:</i>	TE CC-line that detected <i>Attach</i> .

## 5. GENERATOR OPERATION

When used as a *Generator* UCD-300 Series test equipment act as DisplayPort, HDMI or USB-C DisplayPort Alt Mode Source or Transmitter devices.

User is selecting device role when opening the Device when launching UCD Console. Selecting *DP Reference Source*, *HDMI Reference Source* or *DP Alt Mode Reference Source*, UCD Console operates as Generator.

### Functionality Tabs

UCD Console features are presented in tabs. Standard tabs are similar in all functional roles, Interface Specific tabs present features and controls that are only available for a particular interface.

Some of the tabs are enabled by default, some only when an applicable license is included.

#### Standard Tabs

Generator role features six standard tabs:

- Video pattern generator (Pattern Generator).
- Content Playback (Playback)
- EDID editor (EDID).
- HDCP status monitor and control (HDCP).
- Sink DUT Testing

#### Interface Specific Tabs

Based on the connected UCD device, additional interface specific tabs will be available.

##### [UCD-301, UCD-323 and UCD-340: DP and USB-C DP Alt Mode Reference Source](#)

- Status information and control of the downstream link (Link).
- DPCD monitor (DPCD)

##### [UCD-301 and UCD-323: HDMI Reference Source](#)

- Status information and control of the downstream link (Link).
- SCDC monitor (SCDC)

##### [UCD-340: USB-C Reference Source](#)

- USB-C Monitoring (USB-C)

---

**Note:** Some of the tabs are enabled by default, some only when an applicable license is included. Please refer to Appendix B Licensing of this document for description of features and licensing.

---

## Standard Tabs

### Pattern Generator Tab

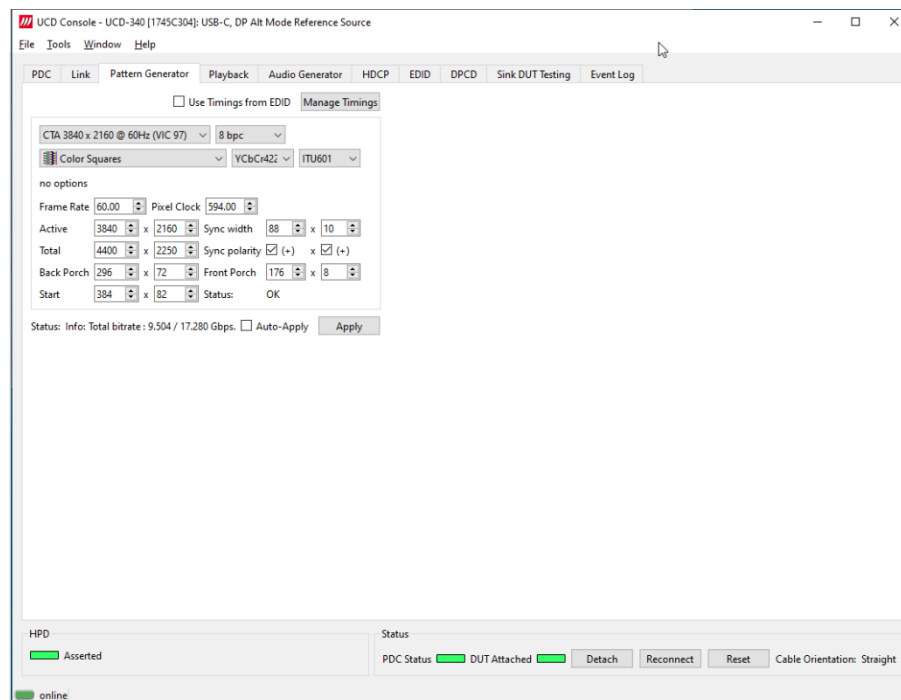

<i>Use timings from EDID</i>	UCD reads the EDID of the connected Sink and lists only timings that are featured there.
<i>Manage Timings</i>	Please see chapter <i>Manage Timings</i> later in this manual
<i>Info</i>	Used link payload / Total link capability in Gbps
<i>Auto-Apply</i>	In order to avoid sourcing invalid video mode combinations new settings are being validated when the user is clicking Apply. Automatic validation will be applied when <i>Auto-Apply</i> is checked.
<i>Apply</i>	Apply recent changes

## Timing and Pattern

Configuration of the video sent in the corresponding stream.

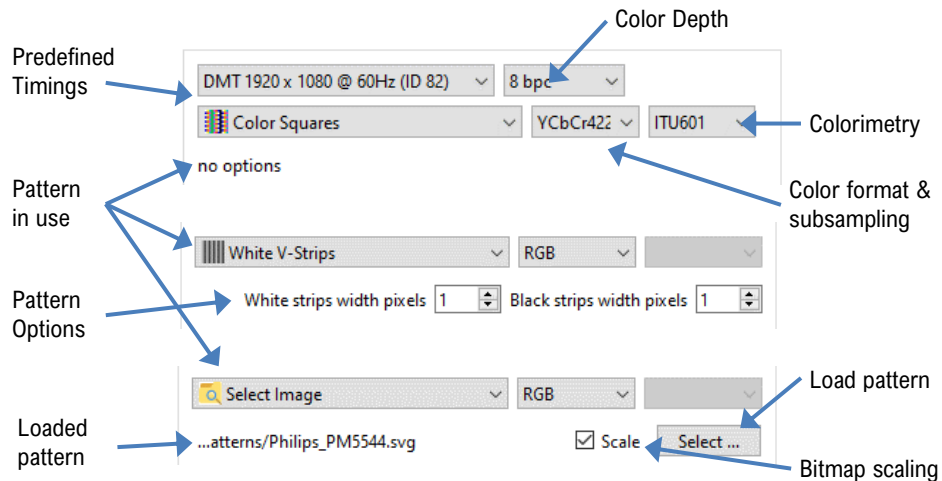

Controls include selection of Predefined Timings, Color Depth, Video Pattern and Pattern Options.

### Predefined Timings

The list includes a set of common fixed video timings. Please find a list of the timings with their major details in [Appendix C](#) of this document. With *Manage Timings* function the user can add timings in the list and limit which timings are shown in the selection.

### Color Depth

Available color depths are: 6, 8, 10, 12 and 16 bpc. Color depth 6 bpc is only available when using RGB color format in DisplayPort or DisplayPort Alt Mode.

### Video Pattern

The selection includes a set of predefined patterns and a possibility to load user defined custom patterns. Please find a description of the available predefined patterns in [Appendix D](#) of this document. By selecting **Disabled** you can have the links activated but no video data transferred.

### Custom Image Patterns

BMP, PNG, and JPG files can be loaded from the PC to be used as custom images. The bitmaps will be aligned to the top left corner, displayed at their original resolution, no scaling, cropped to the used active area.

Please refer to *Link Pattern* in description of *DP Reference Source* or *DP Alt Mode Reference Source* role *Link tab* later in this manual for sending special binary patterns in the link instead of video.

### Pattern Options

Some of the predefined patterns include additional configuration parameters. The controls for the parameters appear below the pattern selection when the pattern in question has been selected. Please find a description of patterns options in [Appendix D](#) of this document.

## MST (UCD-323 special FW configuration)

Multistreaming is available with UCD-323 FW configuration:  
 “DisplayPort Reference Source (MST – 2 streams, HDCP 2.3)”

Check-box for enabling Multi-stream mode and number of streams sourced. Duplicate of controls in *Link* tab. When *MST* is enabled, the streams can also be enabled and disabled from the check-boxes next to stream name.

**Note:** The video modes that can be used in MST streams are limited by the overall capability of the DisplayPort link and the capability of the connected DisplayPort Sink or Branch device.

## Manage Timings

Custom timings can also be created and edited with pop-up *Timing Editor*. Launch the editor by clicking **Manage Timings**.

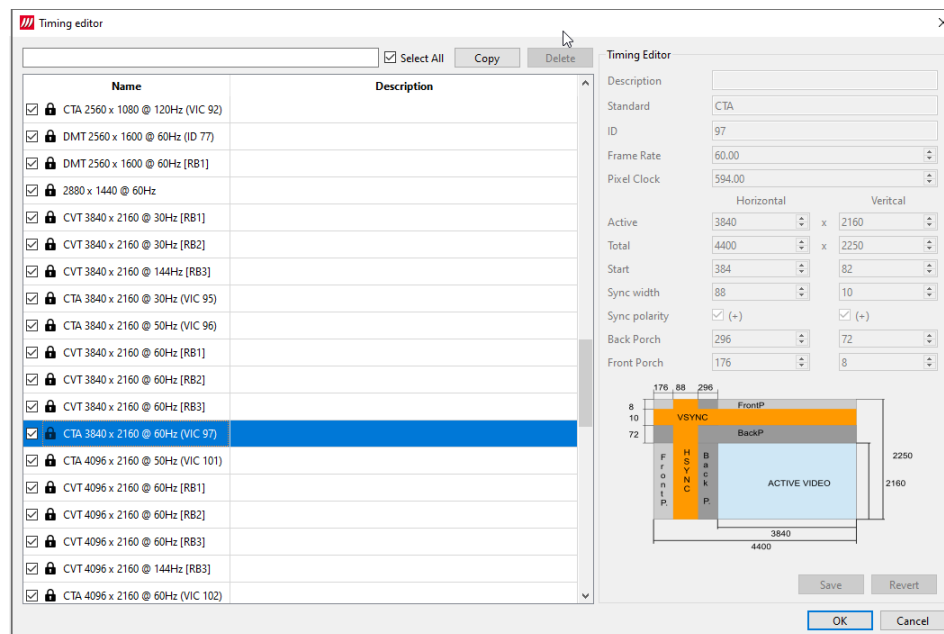

## Customizing Timings List

The list of timings that are shown on the pull-down menu in Pattern Generator and Link tabs can be limited by un-checking the check-box in the left edge of *Name* column. The timings will remain in the list and can be brought back to the pull-down menu, when needed.

## Editing Timings

Video timing Name and Description are shown in the list. Lock icon  indicates that a timing is a fixed timing which cannot be edited or deleted. Custom timings are indicated with a head icon .

**Copy:** Create a new custom timing based on the selected fixed timing.

**Save:** Save changes in the selected custom timing.

The dialog will make a sanity check for the values entered and will warn the user for any combinations that cannot be used.

## Playback Tab

Playback allows for running predefined *Playlist* files. Playlist contains a set of *Scenarios* with definitions of the timing, video pattern, audio content and related metadata packets and their duration.

Sample playlists are included in UCD Console by default. Content can be imported or edited.

Please refer to *Appendix H: Playlists and Scenarios* for a full description of the item.

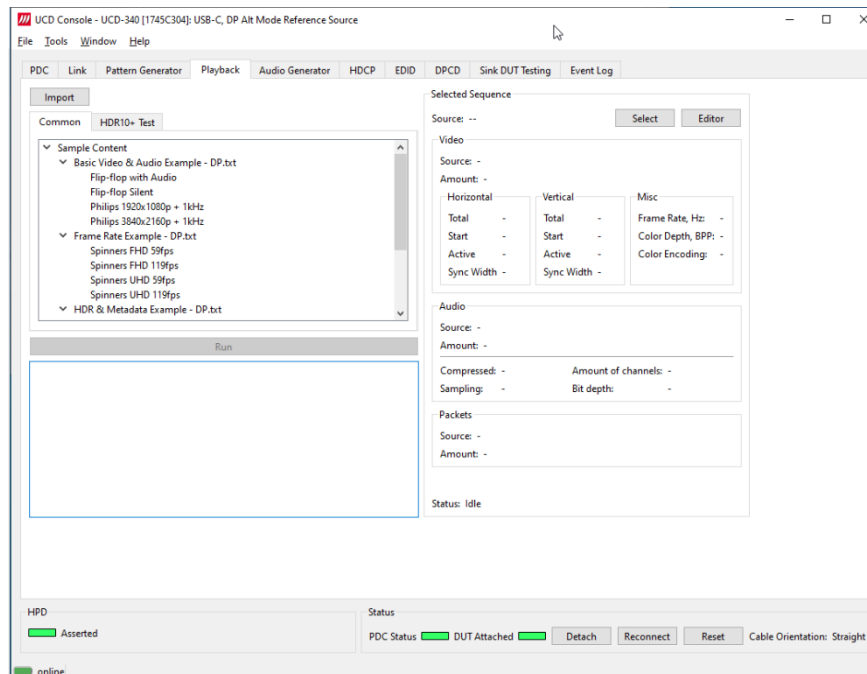

### Playlist

*Playlist* defines the UCD device and the output where the content is played. It lists the played *Scenarios* and their duration.

### Scenario

*Scenario* is an operating structure that allows user to determine a specific sequence of video frames, metadata packets and audio that are going to be played in the defined order.

Playlists and *Scenarios* are stored as human readable text files. The files can be edited using any text-editor software.

### Advanced Playlists

Unigraf UCD devices can also be used as a compatibility test tool for dedicated standards like Dolby Vision™ and HDR10+. Please contact Unigraf for details.

---

**Note:** Please note that Playlists and *Scenarios* are interface technology dependent. The provided examples are also somewhat different for HDMI and DisplayPort.

---

## Selected Sequence

Currently run sequence and its details is indicated in *Selected Sequence* on the right. The executed steps of the scenario are listed in the *Status Log*.

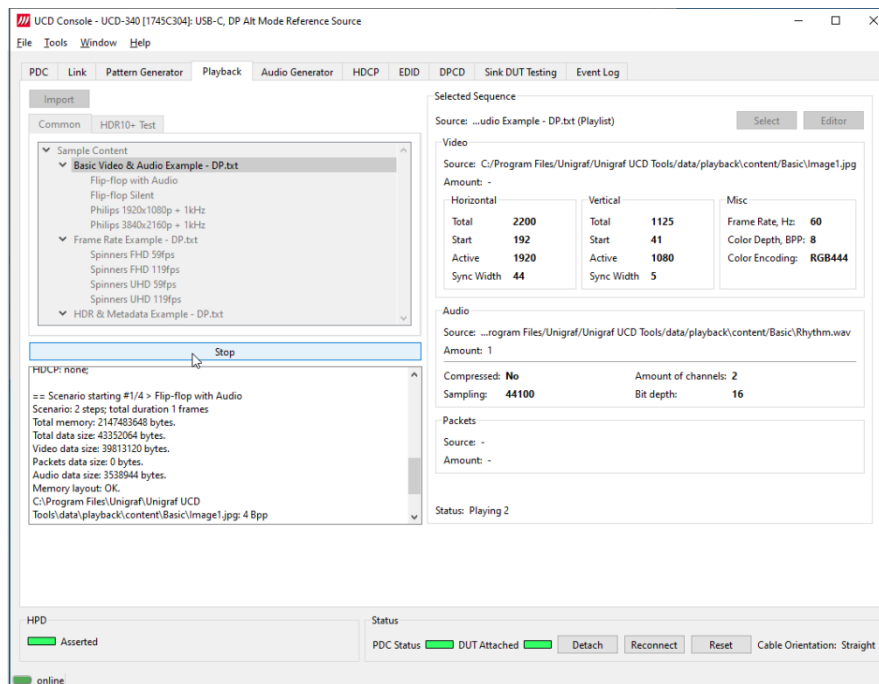

## Scenario Editor

Details of a Scenario can be edited with *Scenario Editor*. Please refer to *Appendix H: Scenarios and Playlists* later in this manual for details of Scenarios.

If you would like to add custom playlists or scenarios into the list in Playback tab, please contact Unigraf.

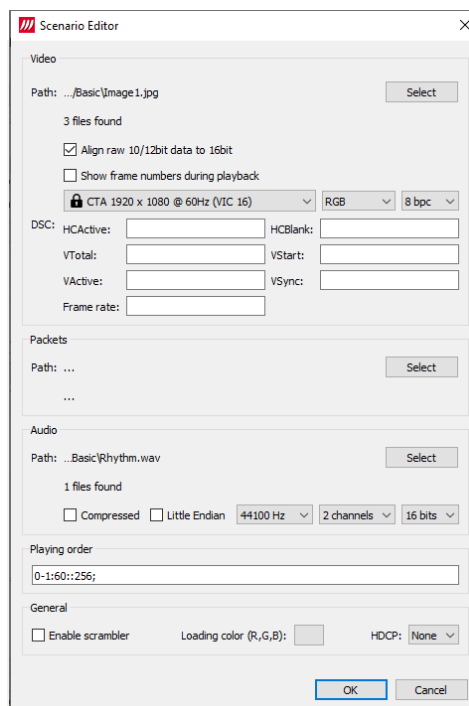

## Audio Generator Tab

Audio generator allows the user to play LPCM audio generated internally or from files in WAV format.

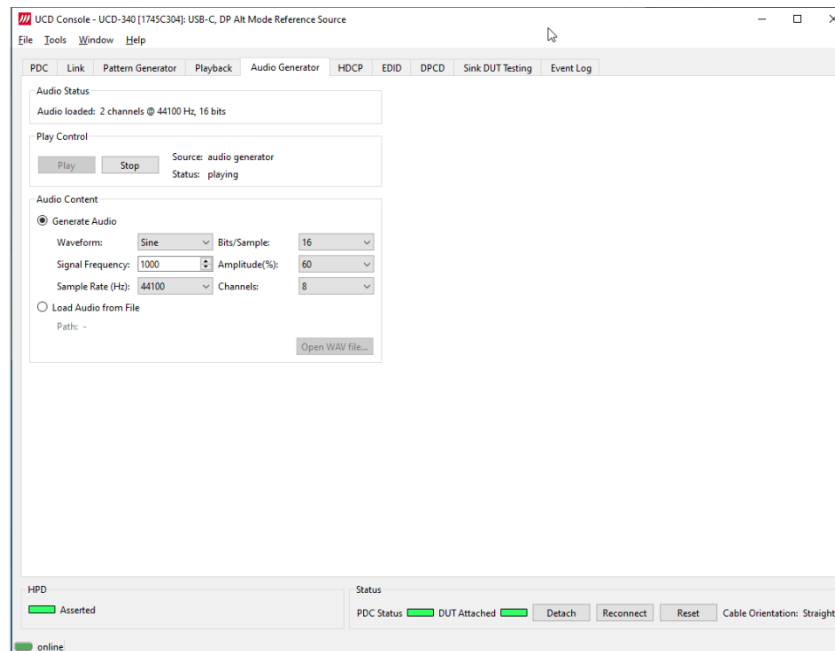

To load internally generated audio, select **Generate audio**, and adjust the controls to the desired audio format.

To load an audio file from your PC, select Load audio from file, click the **Open WAV file...** button, browse and select the file and click **Open**

To play the selected audio content, click the **Play** button.

The content will be looped until the **Stop** button is clicked.

Audio Status in the top of the tab indicates the type of the currently played audio content.

### Audio Content

Sent audio can be generated internally or used a WAV file loaded from the PC.

In case of a WAV audio file, the parameters stored in the file will be used. When generating audio internally, the user sets the details of the LPCM Audio signal.

<i>Waveform</i>	Selection of audio waveform: Sine, Sawtooth, Square, or Incremental
<i>Signal Frequency</i>	Setting audio signal frequency in Hz
<i>Sample Rate (Hz)</i>	Selection of audio sampling rate: 32000, 44100 (default), 48000, 88200, 96000, 176400, 192000
<i>Bits/Sample</i>	Selection of sample bit depth: 16, 24
<i>Amplitude(%)</i>	Selection of audio amplitude: 10%, 20%, ..., 90%, 100%
<i>Channels</i>	Selection of sent audio channels: 1, 2, ..., 7, 8. When selecting 1 or 2 audio channels '1 and 2 channel LPCM Audio mode' is used and when 3 and more channels '3- to 8-channel LPCM Audio mode' is used.



## HDCE Tab

HDCE tab is the dialog for monitoring the HDCE (for *High-Bandwidth Digital Content Protection*) status and controlling the HDCE capabilities of the UCD-300 device.

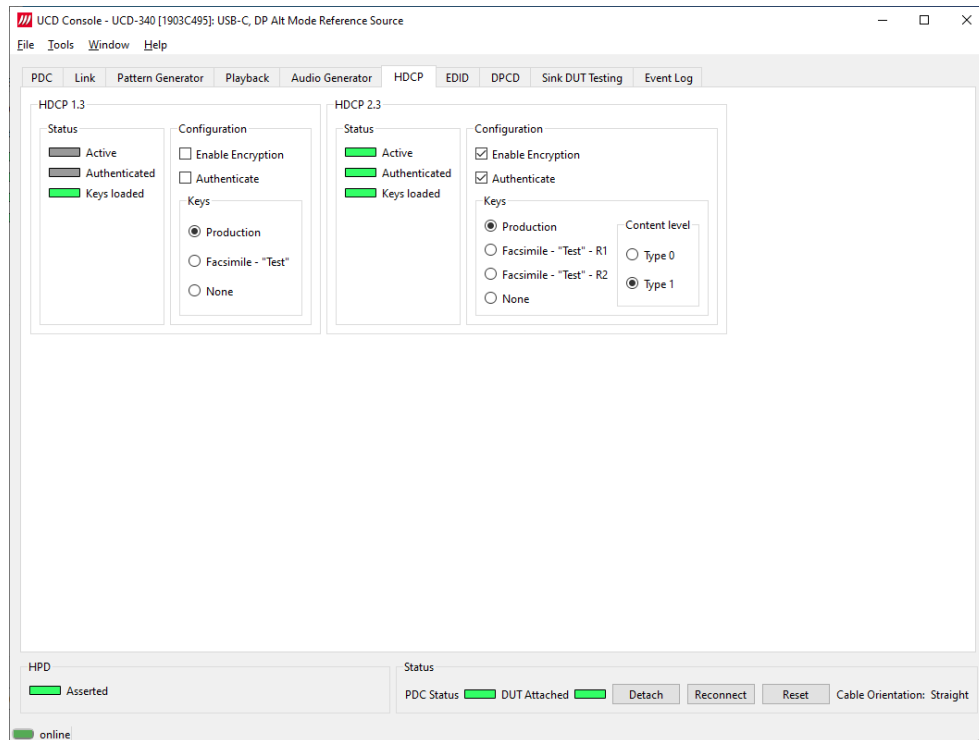

### Status

The status fields indicate the HDCE status of the UCD device.

<i>Active:</i>	The stream between UCD and the downstream sink has been encrypted.
<i>Authenticated:</i>	HDCE handshake between the UCD and the sink unit has been completed successfully.
<i>Keys loaded</i>	HDCE keys are loaded to the UCD unit.

### Configuration

<i>Enable encryption</i>	Check to enable the encryption of the stream between UCD and the downstream sink.
<i>Authenticate:</i>	Perform the HDCE initiation handshake between the UCD and the sink unit.

### Keys

Select between *Production* and *Facsimile* HDCE keys. To remove the keys, select *None*.

### Content level

Selection of Type 1 content ensures that content encryption is done with HDCE version 2.2 or higher.

### HDCE 1.3 / 1.4 vs. HDCE 2.3

UCD-300 devices support by default HDCE 1.3 / 1.4 standard. The functionality for supporting HDCE 2.2 / 2.3 is enabled with HDCE 2.3 Support license

## EDID Tab

EDID Tab provides tools for accessing the EDID and Display ID of the connected DisplayPort sink. There are three basic functions:

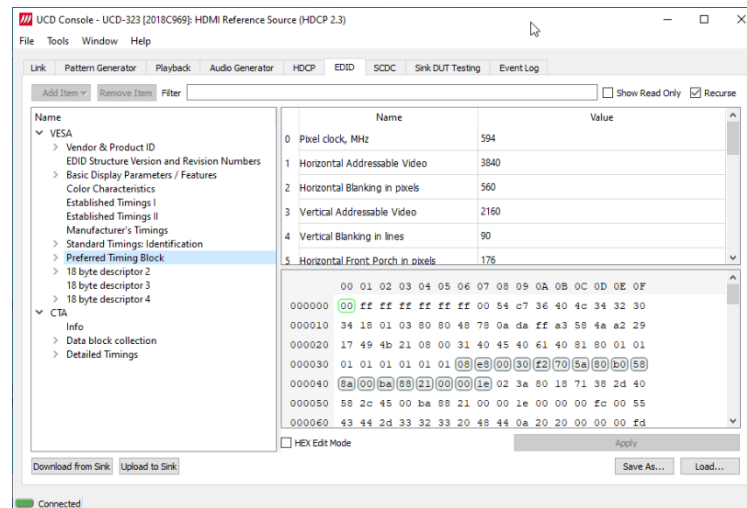

- Load and save EDID data files in the host PC
- Edit the EDID contents either in EDID Editor or in hex format
- Program and read the contents of the EDID of the connected sink

### EDID Files

With **Load...** and **Save as...** a hex EDID file can be read and written from the PC. Please note that the program does not alter the contents of the EDID file or verify its integrity during load and save operation.

---

**Note:** Four blocks (512 bytes) of EDID code is read. If the device is not supporting all four blocks, the non-supported area is replaced with blanks.

---

### EDID Editor

Please see the description of the EDID editor in Chapter [EDID Editor](#) later in this document

## Sink DUT Testing Tab

Please refer to **Appendix E** later in this document for description of the tests available. Sink DUT Testing enables the execution of HDCP 2.3 Compliance Tests for a DP Sink DUT. Sink DUT Testing enables testing of a DP Sink DUT. Please refer to **Appendix E** of this document to get a full definition of the Test Cases and test parameters.

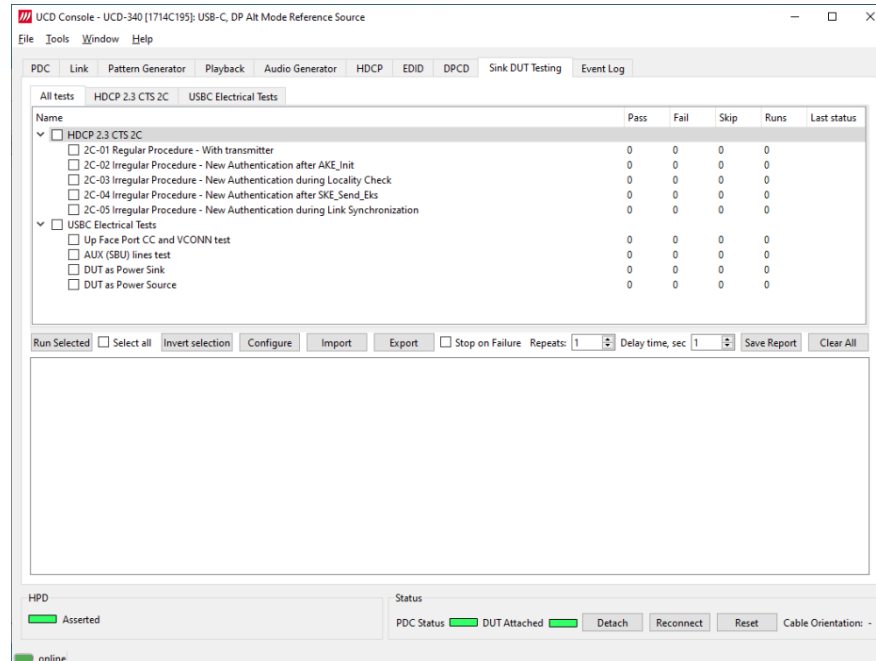

Select the tests for execution by clicking the corresponding row.

<i>Run Selected:</i>	Click to start selected tests. By clicking <i>Abort</i> the sequence is stopped.
<i>Select all:</i>	Select all tests in the selected tab.
<i>Invert selection:</i>	Invert selection of tests selected. Hint: To clear all selections, click <i>Select all</i> and then <i>Invert selection</i> .
<i>Configure:</i>	Clicking opens a dialog for defining the test parameters for the selected test set. Please refer to <i>Test Parameters</i> below for details.
<i>Import:</i>	Load saved test parameter files (*.td or *.json).
<i>Export:</i>	Save test parameters for later use or for use in test automation. For saving parameters for later use in UCD Console, either format can be used. For saving parameters for TSI scripting, please use *.td files. For use with Python applications, please use *.json files.
<i>Stop on Failure:</i>	Stops execution of the selected tests if one of the tests fail
<i>Repeats:</i>	Repeat the selected test several times
<i>Delay time:</i>	Delay in seconds between individual tests.

At the completion of each test the result of the test is indicated in the matrix on the right hand side of the test panel. For each test the matrix lists the number of occurrences of each result and the number of tries performed.

<i>Save Report:</i>	Click to generate a HTML report file for sharing the results with other parties for viewing without UCD Console.
<i>Clear Log:</i>	Clear the test log and the results matrix

## Test Parameters

Each test set has its dedicated set of test parameters. To open a dialog for defining the parameters click **Configure**.

Description of parameters for each test set can be found within the description of tests in Appendix E of this document.

## Saving Test Parameters

Test parameters can be saved in various ways.

- Export parameters in *Sink DUT Testing* tab to a \*.td file for later use in UCD Console or with TSI scripting or sharing.
- Export parameters in *Sink DUT Testing* tab to a \*.json file for later use in UCD Console or with Python applications or sharing.
- Save parameters in *Configure* dialog as Presets to be later used in Console. Please find a description below.

## Presets

In all *Configure* dialogs the selected parameters can be saved as Presets. Please click **Presets...** to save or recall a configuration.

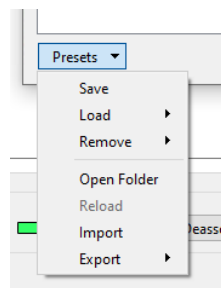

## DP and DP Alt Mode Reference Source

When roles *DP Reference Source* or *DP Alt Mode Reference Source* are in use, the following interface specific tabs are available.

- Status information and control of the downstream link (Link)
- DPCD monitor (DPCD)

### DP Link Tab

Link tab shows the status and control items for the DisplayPort link.

The screenshot displays the UCD Console interface for a DisplayPort Reference Source (SST, HDCP 2.3). The interface is divided into several sections:

- Link Status:** Shows Lanes (count = 4) with a progress bar for lanes 0, 1, 2, and 3. CR/SL/EQ and VS/PE (level) are both 0/0. Error count is 0. ILA, EQ\_ILA, CDS\_ILA, and LT\_FAIL are all active.
- Bit rate:** 5.4 Gbps, Link Mode: 8b/10b.
- Framing mode:** Enhanced, Scrambling: Enabled.
- MST mode:** Disabled, SSC status: Not supported.
- DSC status:** Not supported, FEC status: Not supported.
- Send ACT:** Button to send the Active Content Transfer (ACT) signal.
- Link Overrides:** Voltage Swing (level) and Pre-emphasis (level) are both set to 0.
- Link Pattern:** Active Video is selected.
- Stream Info:** A table showing various stream parameters.
- HPD:** Asserted.
- Link Configuration:** DP1.4 Number of Lanes is set to 4, and DP 1.4 Bitrate is set to 5.40 Gbps.
- Link Options:** Enhanced Framing Mode is checked.
- Scrambler reset:** Auto is selected.
- HDCP Status:** Active, Authenticated, and Keys loaded are all active.
- HDCP Configuration:** Enable Encryption and Authenticate are checked.
- Link Training:** Button to initiate link training.

Stream Info	Framerate	HTotal	HStart	HActive	HSync	VTotal	VStart	VActive	VSync	CEF	BPC	CRC	MVID/NVID
	50.000	5280	216	4096	88 (+)	2250	82	2160	10 (+)	RGB/Legacy RGB mode	8	3F3A 967D A7BF	008CCD/008000

## Link Status

Link Status displays the status of the link training and the link parameters negotiated between the connected Sink and the UCD Source. It also lists status of other link modes. The data is retrieved from the DPCD status registers of the connected Sink. The status is updated automatically.

**Link Status**

Lanes (count = 4):	0	1	2	3
CR/SL/EQ	<span style="color: green;">■</span>	<span style="color: green;">■</span>	<span style="color: green;">■</span>	<span style="color: green;">■</span>
VS/PE (level)	0/0	0/0	0/0	0/0
<a href="#">Error count (click to read):</a>	-	-	-	-

---

ILA: ■ EQ\_ILA: ■ CDS\_ILA: ■ LT\_FAIL: ■

---

Bit rate:	<b>5.4 Gbps</b>	Link Mode:	<b>8b/10b</b>
Framing mode:	<b>Enhanced</b>	Scrambling:	<b>Enabled</b>
MST mode:	<b>Disabled</b>	SSC status:	<b>Not supported</b>
DSC status:	<b>Not supported</b>	FEC status:	<b>Not supported</b>

<i>Lanes:</i>	Indicates the number of lanes used for DisplayPort or DisplayPort Alt Mode.
<i>CR/SL/EQ:</i>	LED indicators for status of Clock Recovery / Symbol Lock / Channel Equalization
<i>VS/PE (level):</i>	Voltage Swing / Pre-emphasis level
<i>Error count:</i>	Content of DPCD Error Count registers
<i>ILA:</i>	LED indicator for 'Inter lane Alignment Done'
<i>EQ_ILA:</i>	LED indicator for 'Link Training Concurrent flow is finished by the most-downstream DPRX'.
<i>CDS_ILA:</i>	LED indicator for 'Clock and Data Switch flow is finished by the most-downstream DPRX'.
<i>LT_FAIL:</i>	LED indicator for 'Link Training failed'.
<i>Bit rate:</i>	Currently enabled link bit rate
<i>Link mode:</i>	Currently enabled channel coding (128b/132b or 8b/10b)
<i>Framing mode:</i>	Currently enabled Framing Mode (Normal or Enhanced)
<i>Scrambling:</i>	Status of link data scrambling (Enabled or Disabled)
<i>MST mode:</i>	Status of the Multistreaming (MST) mode (only in UCD-323 special FW configuration)
<i>SSC Status:</i>	Not Supported
<i>DSC Status:</i>	Not Supported
<i>FEC status:</i>	Not Supported

<i>Send ACT:</i>	Force sending an Allocation Change Trigger (ACT) sequence over the Main-Link
------------------	--

## Link configuration

Set target capabilities for the link training. Click **Link Training** to apply.

**Link Configuration**

DP1.4 Number of Lanes

1  2  4

DP 1.4 Bitrate, Gbps

1.62  2.70  5.40

**Link Options**

Enhanced Framing Mode

**Scrambler reset**

Auto  FFFFh (DP)  FFFFh (eDP ASSR)  Custom 0x

**Link Training**

<i>DP1.4 Number of Lanes</i>	Lane count used when 8b/10b link coding is selected in LT
<i>DP1.4 Bitrate, Gbps</i>	Link rate used when 8b/10b link coding is selected in LT
<i>Scrambler Reset:</i>	Selection of the value to which the Linear Feedback Shift Register (LFSR) is reset during scrambler reset
<i>Enhanced Framing Mode</i>	Enable Enhanced Framing Mode

## Link Pattern

Select between Active video and audio, Idle pattern, or special bit patterns.

**Link Pattern**

Active Video ▼

**Apply**

<i>Active Video</i>	Transmit Video Pattern, Audio and Metadata
<i>Idle Pattern</i>	Link is active but no stream data is being transmitted
<i>Training Pattern 1</i>	Send Link Training Pattern Sequence 1 (TPS1)
<i>Training Pattern 2</i>	Send Link Training Pattern Sequence 2 (TPS2)
<i>Training Pattern 3</i>	Send Link Training Pattern Sequence 3 (TPS3)
<i>Training Pattern 4</i>	Send Link Training Pattern Sequence 4 (TPS4)
<i>PRBS7</i>	Send PRBS7 Link Quality Test Pattern
<i>HBR2 Compliance EYE pattern</i>	Send HBR2 Compliance EYE pattern
<i>SER (Symbol Error Rate)</i>	Send Symbol Error Rate Measurement pattern
<i>Force Video</i>	Character error messages from sink will not interrupt video transmission.
<i>Force Idle</i>	Link Training and Active Video will not be initiated even after a re-plug

## Link Overrides

Override Voltage Swing and Pre-emphasis selected during link training. Click **Apply** to validate changes.

**Link Overrides**

Voltage Swing (level):  0  1  2  3

Pre-emphasis (level):  0  1  2  3

Active Video ▼ **Apply**

## Stream Info

Stream Info is retrieved from the Main-Stream Attributes (MSA) of the monitored stream.

Stream Info												
Framerate	HTotal	HStart	HActive	HSync	VTotat	VStart	VActive	VSync	CEF	BPC	CRC	MVID/NVID
50.000	5280	216	4096	88 (+)	2250	82	2160	10 (+)	RGB/Legacy RGB mode	8	3F3A 967D A7BF	008CCD/008000

The content of *Stream Info* table can be copied by right-clicking on the table and selecting **Copy**.

<i>Framerate</i>	Vertical refresh rate
<i>HTotal</i>	Horizontal total of transmitted main video stream, measured in pixel count.
<i>HStart</i>	Horizontal active start from leading edge of HSync, measured in pixel count.
<i>HActive</i>	Horizontal active, number of active pixels in video line
<i>HSync</i>	HSync width, measured in pixel count.
<i>VTotat</i>	Vertical total of transmitted main video stream, measured in line count.
<i>VStart</i>	Vertical active start from leading edge of VSync, measured in line count.
<i>VActive</i>	Vertical active, number of active lines in video frame
<i>VSync</i>	VSync width, measured in line count.
<i>CEF</i>	Used color mode: Color format + subsampling / colorimetry
<i>BPC</i>	Color depth in bits per color (BPC)
<i>CRC</i>	16-bit Cyclic redundancy check (CRC) value per color component calculated from active pixels
<i>MVID/NVID</i>	Mvid and Nvid video time stamp values

## HDCP Status

Copy of the status from HDCP Tab. Please refer to chapter *HDCP Tab* later in this document for detailed description.

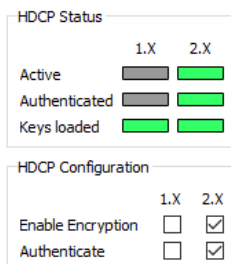

## HDCP Configuration

Enable and disable HDCP 1.3 or HDCP 2.3 encryption. Duplicates of the controls found in HDCP tab.

## HPD

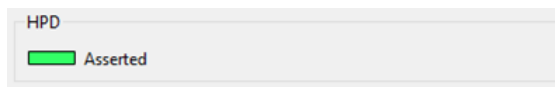

**Asserted:** LED indicates status of Hot Plug Detect (HPD) signal



## DPCD Tab

DPCD tab is a tool for monitoring and editing the DPCD registers of the connected DisplayPort or DisplayPort Alt Mode Sink.

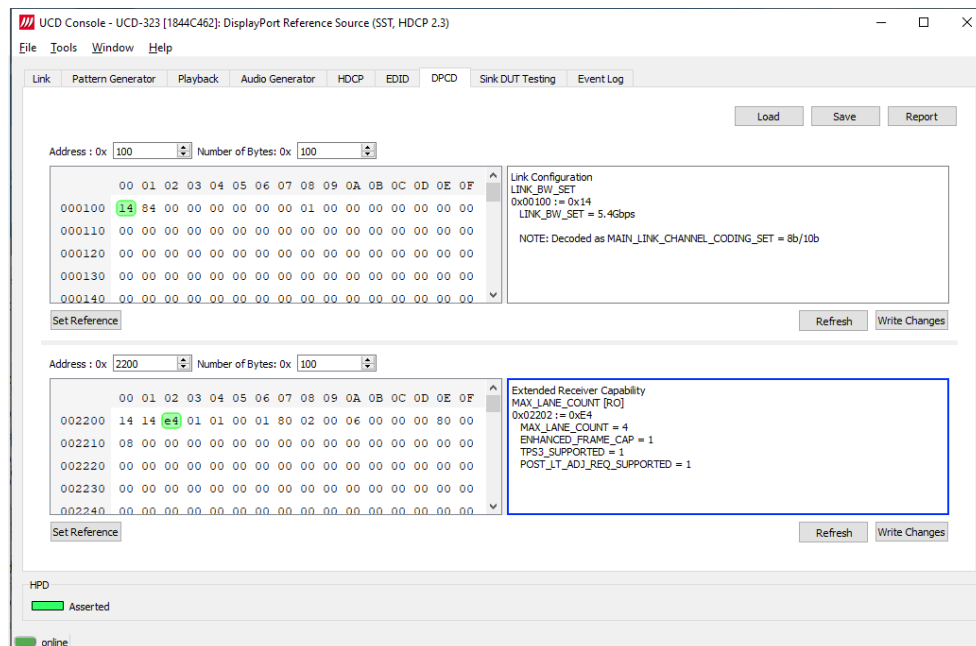

The *DPCD Decoder* panels on the right show the interpretation of the DPCD byte selected on the monitoring windows. The selected byte is shown with a green background.

<i>Refresh:</i>	Re-read the data from the DPCD registers to the window in question
<i>Write Changes</i>	Write the portion of data shown in the window in question to the DPCD registers.
<i>Set Reference</i>	Store currently shown data as a reference for comparison

When the data is *Refreshed* from the DPCD registers the changed bytes will be highlighted with **blue** color.

The fields edited by the user will be highlighted with **red** color.

### Saving and Loading DPCD Content

DPCD data in the selected address areas can be saved as a file in your PC. There are two alternative formats listed below. Please select the format when saving:

- Binary *DPCD Fata File* format (\*.DPD). This is Unigraf proprietary format. You can also load the DPCD content stored in this format.
- *HEX Dump* (\*.HEX) in a human readable text format.

*Save:* Store DPCD content to a file.

*Load:* Recall DPCD data saved in a Data File (\*.DPD) format to the editor.

## HDMI Reference Source

When roles *DP Reference Source* or *DP Alt Mode Reference Source* are in use, the following interface specific tabs are available.

- Status information and control of the downstream link (Link)
- SCDC monitor (SCDC)

### HDMI Link Tab

Link tab is enabled by default.

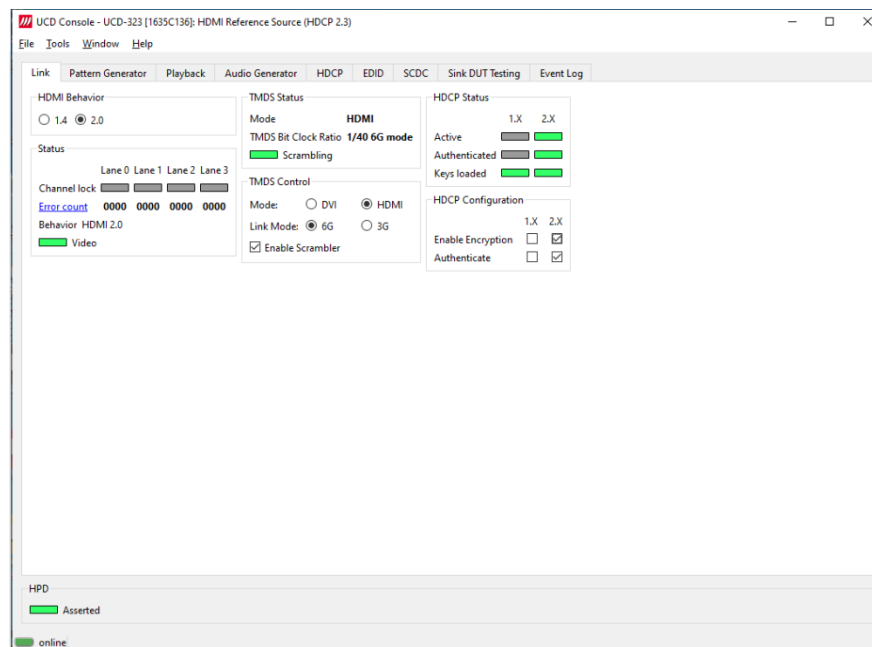

#### HDMI Behavior

Selection of the HDMI version to be used (HDMI 1.4 or HDMI 2.0).

#### Status

<i>Channel lock</i>	Indication of channel lock status in TMDS links 0 to 2
<i>Error count</i>	Status of SCDC Error Count Registers
<i>Behavior</i>	HDMI operation mode (HDMI 1.4 or HDMI 2.0)
<i>Video:</i>	Video data available

#### TMDS Status

<i>Mode</i>	TMDS mode (HDMI or DVI)
<i>TMDS Bit Clock Ratio:</i>	Status of TMDS_Bit_Clock_Ratio bit in SCDC – TMDS Configuration (1/10 or 1/40)
<i>Scrambling:</i>	Status of TMDS_Scrambler_Status bit in SCDC – TMDS Scrambler Status (1=LED on; 0=LED off)

## HDCP Status

Copy of the status from HDCP Tab. Please refer to chapter *HDCP Tab* later in this document for detailed description.

## HDCP Configuration

Enable and disable HDCP 1.3 or HDCP 2.3 capability of UCD-422 Sink. Duplicates of the controls found in HDCP tab.

## HPD

The status LED indicates the state of the HPD signal Asserted (logical "high") or De-asserted (logical "low").

## SCDC Monitor

SCDC monitor presents content of HDMI Status and Control Data Channel (SCDC) structured by its address range.

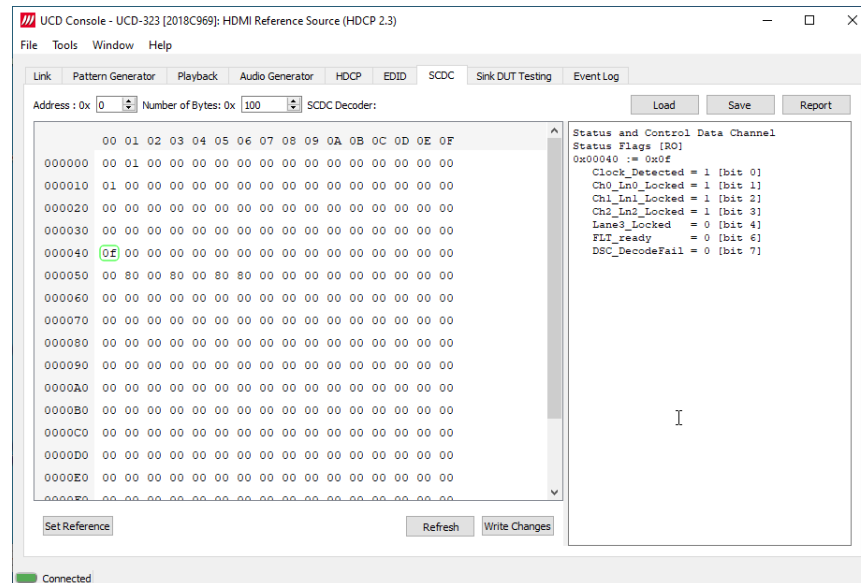

The *SCDC Monitor* panel on the right hand side shows the interpretation of the SCDC byte selected on the monitoring windows. The selected byte is shown with a green outline.

Click **Refresh** to re-read the data from the DPCD registers to the window in question.

Click **Write Changes** to write the portion of data shown in the window in question to the DPCD registers.

▶ Click **Set Reference** to store currently shown data as a reference for comparison.

When the data is *Refreshed* from the DPCD registers the changed bytes will be highlighted with blue color.

The fields edited by the user will be highlighted with **red** color.

### Saving and Loading SCDC Content

SCDC data in the selected address areas can be saved as a file in your PC. There are two alternative formats listed below. Please add the intended format when saving:

- Binary *SCDC Fata File* format (\*.DPD). This is Unigraf proprietary format. You can also load the SCDC content stored in this format.
  - *HEX Dump* (\*.HEX) in a human readable text format.
- ▶ Click Save to select the location and the format of the file.
- ▶ Click Load to load SCDC data saved in SCDC Data File (\*.DPD) format to the editor.
- ▶ To program the data into the SCDC registers of UCD Local Sink click Write **Changes**.

# USB-C Monitoring

Role:	Product:
USB-C DP Alt Mode Reference Source (USB-C TX)	UCD-340

When *USB-C DP Alt Mode Reference Source* role is in use, the following interface specific tabs are available.

- USB-C Power Delivery (PDC)

## USB-C Power Delivery Tab

When UCD-340 is used in *DP Alt Mode Reference Source* role, *USB-C Power Delivery* tab is available. The content of *USB-C Power Delivery* tab is similar to the tab available when in UCD-340 is used in *DP Alt Mode Reference Sink* role.

Please refer to chapter *USB-C Monitoring* in section 4. *Analyzer Operation* earlier in this document

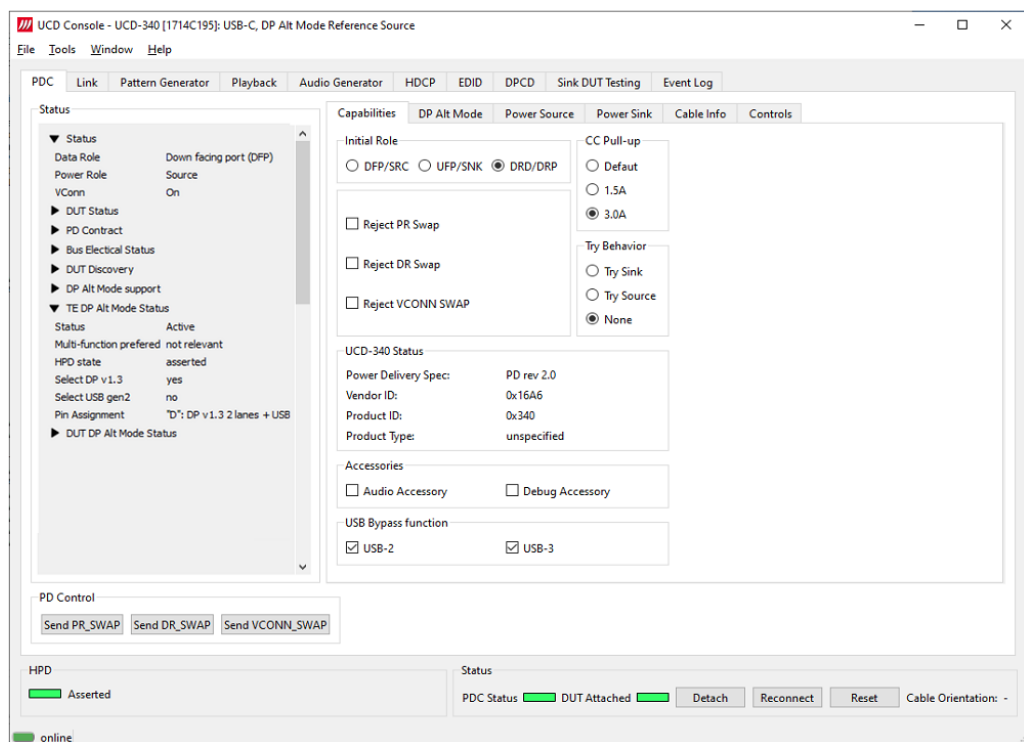

## 6. EVENT LOG

*Event Logger* (Event Log) collects time stamped information from the display interface. The type of data items logged is dependent on the display interface used and the role selected.

Event Log dialog is divided into two panels: the left panel lists all transactions, and the right panel shows the parsed transaction data for the line selected in the list on the left.

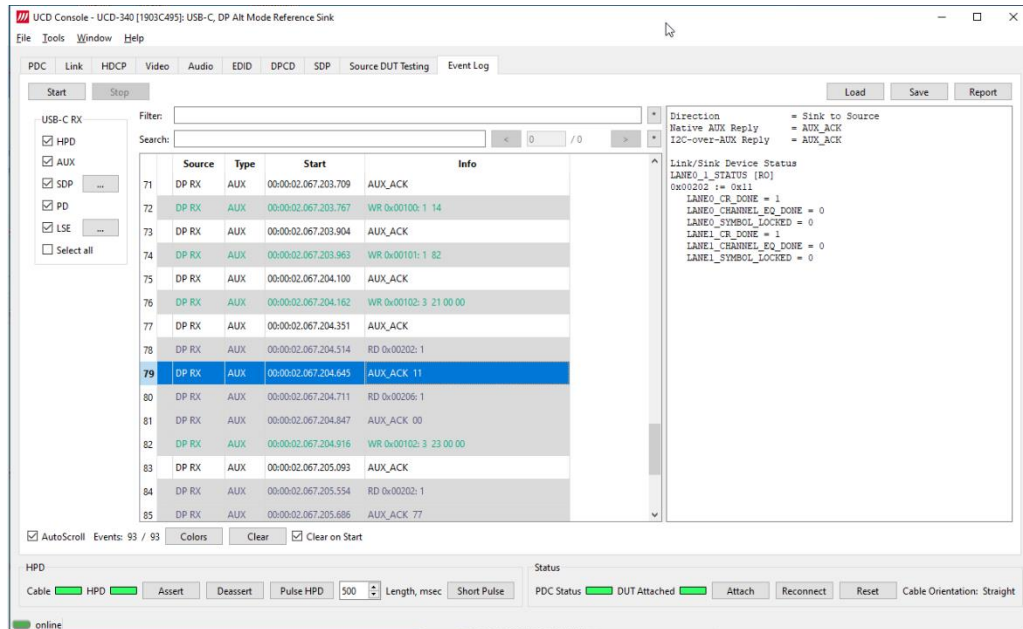

Role	Logged Events
DP Sink DP Alt Mode Sink	HPD, SDP, AUX Transactions
HDMI Sink	HPD, Packets, I2C, CEC
DP Source DP Alt Mode Source	HPD, AUX Transactions
HDMI Source	HPD, I2C, CEC
DP Alt Mode Sink DP Alt Mode Source	PD, LSE

- Start:* Starts event logging and stop it by clicking *Stop*.
- Save:* Save transactions as Event Log data.
- Load:* Load saved Event Log data
- Report:* Store event logs as html reports to be shared and viewed with any web browser.
- AutoScroll:* When selected, transaction list is scrolled vertically, and the latest transaction is shown as the last item of the list. When not selected, the items shown before clicking *Start* will be shown.
- Events* Number of events detected
- Clear:* Click to clear transaction list. When *Clear on Start* is selected, the list is cleared when clicking *Start*.

## Logged Events

### HPD

Status and status changes of Hot Plug Detect (HPD) signal

### SDP

Secondary-data Packets received in DP Main-Link. Click the  button to open the *Event Filter Dialog*. The dialog enables filtering of SDP packets. In the dialog, the reference to Packet Type Value is indicated in square brackets “[ ]”.

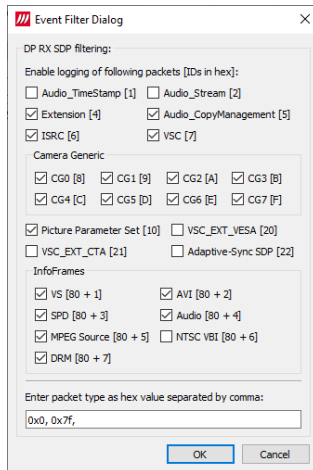

### AUX

DP AUX Channel transactions.

### Packets

Log metadata sent by Source device in HDMI lanes

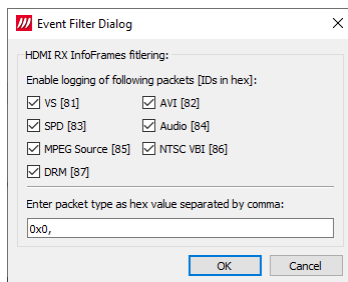

### I2C

Log data sent over I2C communication lines of HDMI interface

### PD

Log USB-C PD communication messages

## LSE

Low Speed Electrical logger captures the Voltage and Current on the low speed lanes of the USB-C connector including CC, VBUS, VCONN, and SBU.

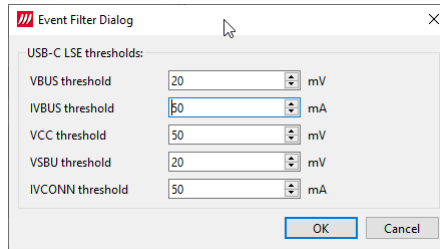

In Event Filter Dialog the user can set the noise threshold values. Only measurement exceeding the corresponding threshold will be logged.



## Event Transaction List

Transaction data in Transaction List is ordered in columns. Each column provides additional information about the data line, facilitating its viewing and interpretation.

**Start:** Each line is identified by its timestamp, marking the instant when an event or error was detected, or when a data transaction got started. The timestamp can be displayed as a time delay from the start of the acquisition (absolute) or from the previous line (relative). The timestamp can be displayed in milliseconds or in minutes, seconds, and microseconds.

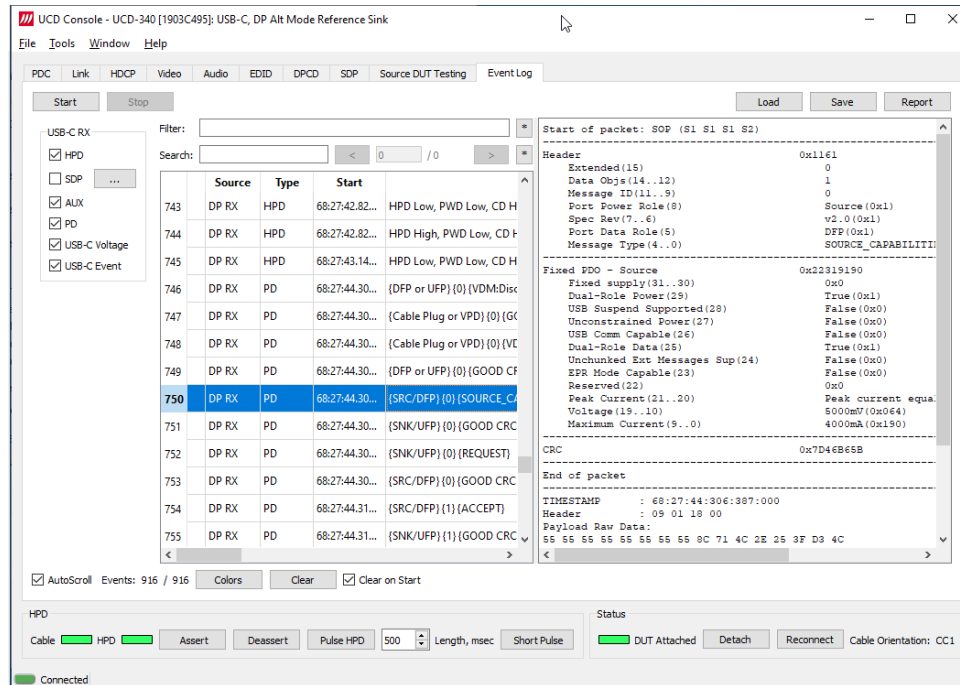

**Start:** Each line is identified by its timestamp, marking the instant when an event or error was detected, or when a data transaction got started. The timestamp can be displayed as a time delay from the start of the acquisition (absolute) or from the previous line (relative). The timestamp can be displayed in milliseconds or in minutes, seconds, and microseconds.

<b>Source and Type</b>	The communication port: DP RX to DP TX
<b>Type</b>	The logged item: HPD, SDP, AUX, MSA Change or VB-ID change
<b>Info</b>	This column provides a short description of the message content

## Customizing Transaction List

User Can change what data is shown in the transaction list by adding and removing columns or limiting the transaction types in the list. User can also color highlight various types of transactions for better readability.

Right-click on the list to open the menu.

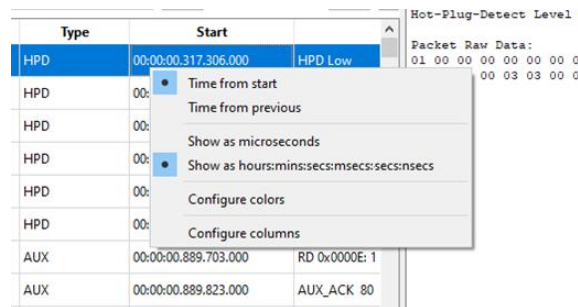

### Configure Start

The time indicated in column *Start* can be either:

- Time from start of the capture
- Time from previous event

The time can be expressed either:

- In microseconds (1/1 000 000 Second)
- Hours : minutes : seconds : milliseconds : nanoseconds

### Configure Colors

*Configure colors* dialog allows the user to highlight various types of transactions in the list by changing character color and background color of the transaction line.

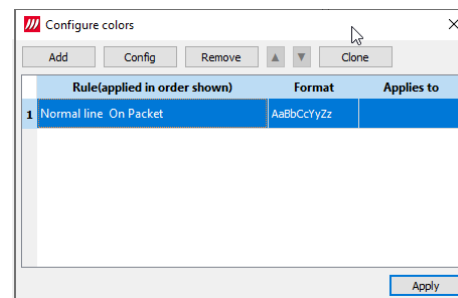

<i>Add:</i>	Add a new color highlight rule
<i>Config:</i>	Modify the selected rule
<i>Remove:</i>	Delete the selected rule
<i>Clone:</i>	Duplicate the selected rule
▲ ▼:	Change order where rules are applied. The rules are applied from the bottom to the top of the list.

## Adding Rules

The color highlight rules are set by transaction type. The content of *Add rules* dialog is dependent on the type of item selected.

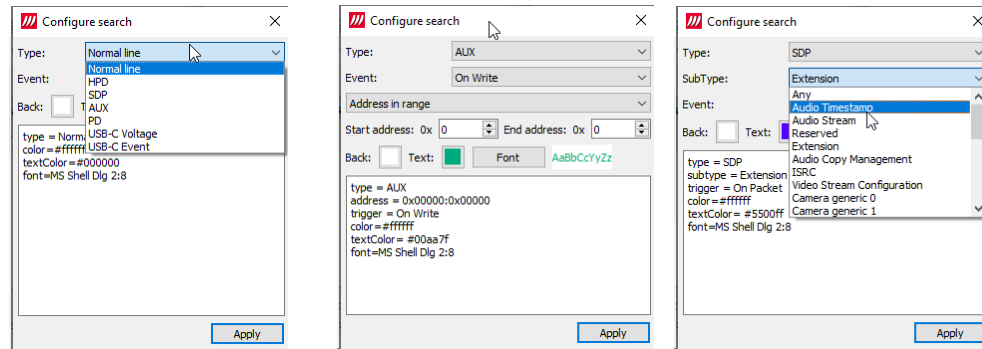

## Configure Columns

In the dialog there are two columns: *Available* and *Active*. An item from Available list can be included in Active columns by selecting it and clicking on the right arrow [>] in the middle of the two columns.

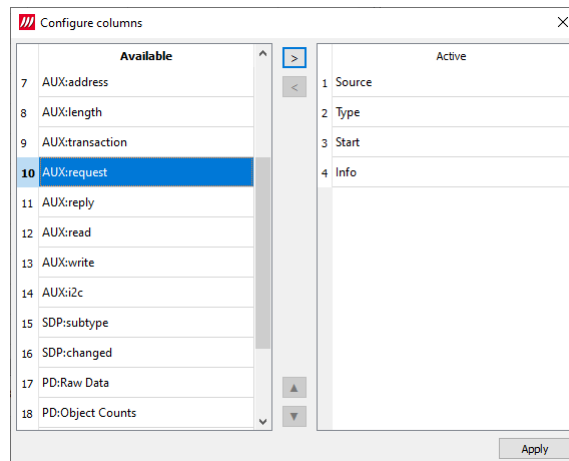

The order of Active items can be changed by selecting an item and moving its position in the list with up ▲ and down ▼ arrows.

## Type Filter

Type filter dialog lists the types of transactions found in the list and allows the user to select which transaction lines are currently shown.

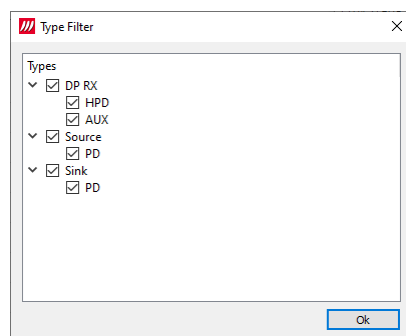

## Quick Filter

By entering a DPCD address in the Quick Filter field on top of the transaction line, the user can limit the list to show only the reads or writes to this DPCD address.

## Parsed Transactions

### HPD

Status and status changes of Hot Plug Detect (HPD) signal.

```
Device ID           = 01 [DP RX]
Hot-Plug-Detect Level = HIGH
PWD Level          = HIGH (DP Tx is connected to Rx and has power applied to AUX pu
Cable Detect Level  = HIGH
```

### AUX (UCD-301, UCD-323, UCD-340)

DP AUX Channel transactions.

```
Direction           = Source to Sink
Native AUX Request  = Write
Length              = 4
Data                = 0A 0A 0A 0A
Address             = 0x00103

Link Configuration
TRAINING_LANE0_SET
0x00103 := 0x0A
  VOLTAGE_SWING_SET = level 2
  MAX_SWING_REACHED = level 0
  PRE_EMPHASIS_SET = level 1
  MAX_PRE-EMPHASIS_REACHED = 0

  NOTE: Decoded as MAIN_LINK_CHANNEL_CODING_SET = 8b/10b

Link Configuration
TRAINING_LANE1_SET
0x00104 := 0x0A
  VOLTAGE_SWING_SET = level 2
  MAX_SWING_REACHED = level 0
  PRE_EMPHASIS_SET = level 1
  MAX_PRE-EMPHASIS_REACHED = 0

  NOTE: Decoded as MAIN_LINK_CHANNEL_CODING_SET = 8b/10b

Link Configuration
TRAINING_LANE2_SET
0x00105 := 0x0A
  VOLTAGE_SWING_SET = level 2
  MAX_SWING_REACHED = level 0
  PRE_EMPHASIS_SET = level 1
  MAX_PRE-EMPHASIS_REACHED = 0

  NOTE: Decoded as MAIN_LINK_CHANNEL_CODING_SET = 8b/10b

Link Configuration
TRAINING_LANE3_SET
0x00106 := 0x0A
  VOLTAGE_SWING_SET = level 2
  MAX_SWING_REACHED = level 0
  PRE_EMPHASIS_SET = level 1
  MAX_PRE-EMPHASIS_REACHED = 0

  NOTE: Decoded as MAIN_LINK_CHANNEL_CODING_SET = 8b/10b
```



## LSE (UCD-340)

Status of USB-C Low Speed Electrical signals

```

Device ID           = 01
Packet size        = 40 [bytes]
Data length        = 40
Vbus TimeStamp     = 02:53:20.750.932.000

Vbus voltage       = 5420 mV [updated]
Vbus currents     = 88 mA
Vcc 1              = 5337 mV [updated]
Vcc 2              = 1680 mV [updated]
Vsbu 1            = 234 mV
Vsbu 2            = 2865 mV
Ivconn            = 5337 mA [updated]
    
```

## Packets (UCD-301, UCD-323)

Log metadata sent by Source device in HDMI stream

```

Packet code: 0x82

Packet Header:
  Packet Length:           13
  Checksum:                57
  Version:                 2
Packet Data:
  Scan Info(0:1)           0 (No Data)
  Bar Data(2:3)            0 (Not present)
  Format Info(4)           0 (Not present)
  Color Space(5:7)        0 (RGB)
  AFD Aspect(8:11)        8 ((ATSC: Same as Picture Aspect Ratio) (
  Coded frame AR(12:13)   0 (No Data)
  Colorimetry(14:15)      0 (No Data)
  Non-U Scaling(16:17)    0 (No Known non-uniform scaling)
  RGB Quant(18:19)        0 (Default (depends on video format))
  E-Colorimetry(20:22)    0 (No data)
  ITC Content(23)         0 (No Data)
  VIC(24:31)              16
  Pixel repeats(32:35)    0 (No repeats)
  ITC Type(36:37)         0 (Graphics)
  YCC Quant(38:39)        0 (Limited range)
  ETB(40:55)              0
  SBB(56:71)              0
  ELB(72:87)              0
  SRB(88:103)             0

Transformed HDMI Data:
82 02 0D 57 00 08 00 10 00 00 00 00 00 00 00 00
00 00 00 00 00 00 00 00 00 00 00 00 00 00 00 38
00 00 00
    
```

## I2C (UCD-301, UCD-323)

Log data sent over I2C communication lines of HDMI interface

```

Message:
HDRX SCDC: RD 0x10:UPDATE[0] 0x0
    
```

## 7. EDID EDITOR

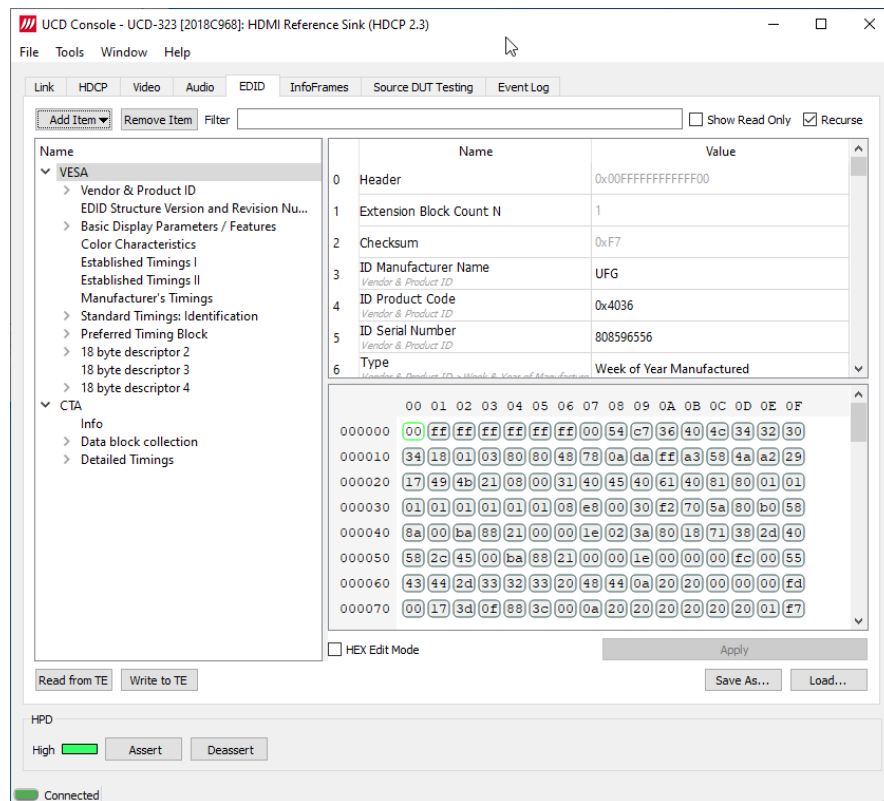

The *EDID Editor* main window is divided into three logical areas. The bottom part additionally contains the command buttons. The top-left portion shows the currently edited E-EDID blocks in a tree-form, and the top-right portion shows an edit control for the currently selected item, possibly a list of sub-keys and their names (The list is not shown for all values) and the HEX-view of the block collection.

### Controls

<i>Add Item:</i>	Add a new EDID or DisplayID block
<i>Remove Item:</i>	Delete the selected EDID or DisplayID block.
<i>Filter:</i>	Show only items having indicated the string in the field name
<i>Show Read Only:</i>	When selected, also automatically created fields are shown
<i>Recurse:</i>	When selected, the whole logical tree of the selected item is parsed on the right hand side list.

The buttons in the bottom of the dialog differ based on the role selected, i.e. is the subject the local EDID or EDID of a connected device.

<i>Read from TE (DP RX):</i>	Read UCD-300 local EDID.
<i>Write to TE (DP RX):</i>	Program UCD-300 local EDID.
<i>Download from Sink (DP TX):</i>	Read EDID of a connected sink device
<i>Upload to Sink (DP TX):</i>	Program EDID of a connected sink device
<i>Load ...:</i>	Load an EDID block collection file from disk.
<i>Save As...:</i>	Save the current block collection to a disk file.

## EDID Editor Features

Practically unlimited number of extension blocks may exist in a single collection. The number of blocks is limited by VESA Specifications and possibly by available system resources. Most EDID blocks contain a structure that is very similar to a tree-structure. The EDID Editor decodes each block into a tree-view of the block. The tree-view then contains all values contained within the EDID block. The contents can then be easily browsed, using only a few mouse clicks. The EDID Editor has a support for automatic variables, such as the block checksum. When the user changes a value in an EDID block, the tool will update the checksum accordingly. The automatic variables appear as read only values for the user. A log print will be made when an automatic variable is updated by the editor.

## Editing Tips

Editing an EDID block is very straightforward, but there are some special cases where the user must know how to accomplish certain types of tasks.

- Double-click the property field to edit
- Red values in the HEX view indicate a changed value.
- **Enter** key will apply text-edit values and combo-box selection.
- In CTA-861 blocks, you can add and remove 18-byte descriptors and CTA data blocks by setting the values “18-byte Descriptors in this block” and “CTA Data block count”.
- Enter hex values with prefix “**0x**” or “**\$**”, no prefix means a decimal value.
- You can always enter HEX or DEC, even if the value is presented as HEX, and/or value range is given in HEX.
- Floating point values must be given with period “.” as decimal separator, even if your localization setting defines decimal separator as comma (or other).
- Remember to click **Set** after changing a bit-value presented as a single check-box if you want the new value applied.

---

**Note:** EDID Editor does not have an *Undo* function. Therefore, it is highly recommended that you back up un-edited EDID contents to a file before editing it.

---



## 8. PACKET EDITOR

### Introduction

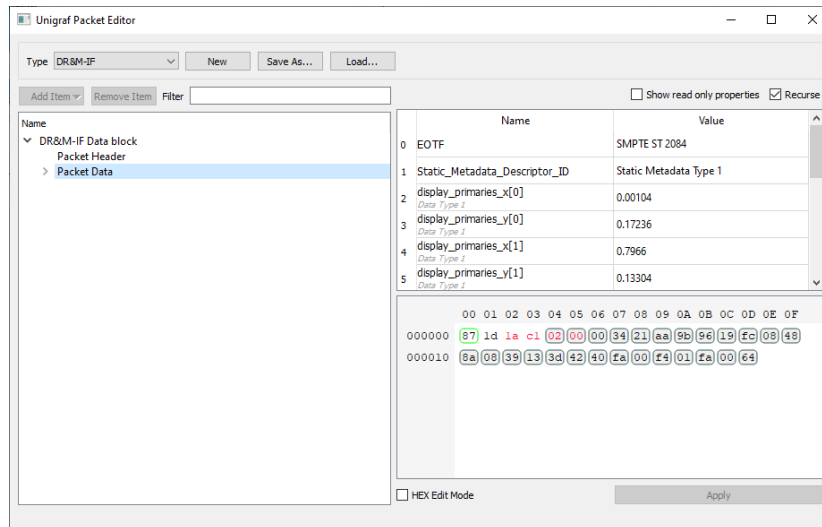

Packet Editor enables creation and editing metadata packets to be included Scenarios played with Playback function.

The types of packets are:

- Audio InfoFrames (Audio-IF)
- Auxiliary Video Information InfoFrames (AVI-IF)
- Dynamic Range and Mastering InfoFrames (DR&M-IF)
- Video timing Extended metadata (EMP-VRR)
- General Control Packet (GCP)
- Source Product Description InfoFrames (SPD-IF)
- Vendor-Specific InfoFrames (VSIF)
- HDMI Forum Vendor-Specific InfoFrames (HF VSIF)
- HDR 10+ Vendor-Specific InfoFrames (HDR10+ VSIF)

## 9. PATTERN EDITOR

### Introduction

Pattern Editor is a tool for editing and debugging Unigraf Custom VTP Pattern scripts.

Please refer to APPENDIX F: VTP PATTERN LANGUAGE later in this document for description of the VTP Pattern Language syntax.

Pattern Editor consists of three tabs:

#### Image Tab

Monitoring the rendering of the VTP pattern script.

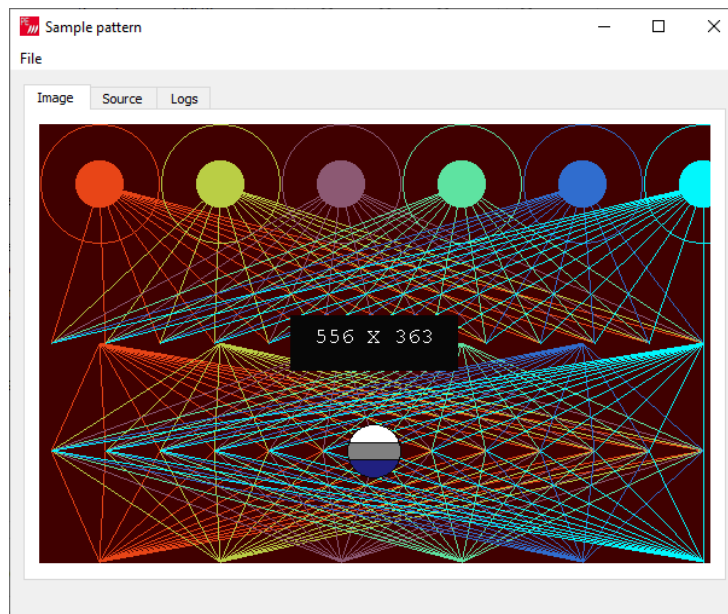

#### Source Tab

Tool for editing VTP Pattern Language script. Click Apply to render the code in the resolution of the preview image in *Image* tab.

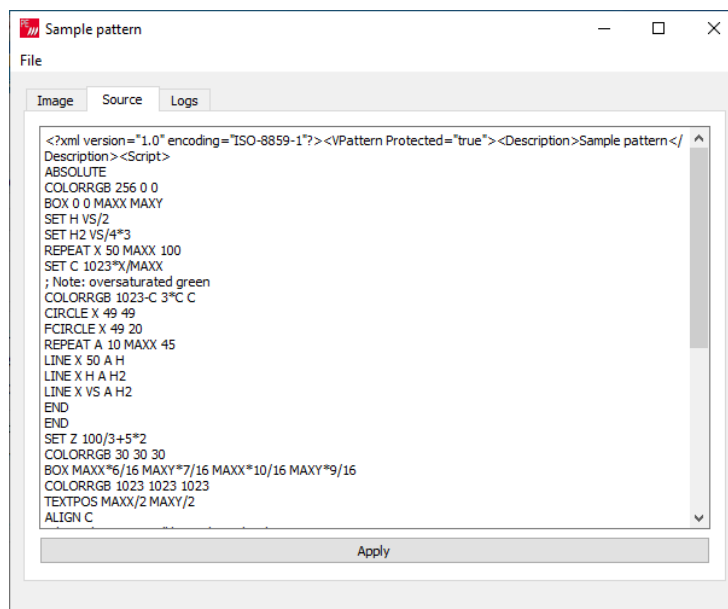

## Logs Tab

Log of the pattern code parsing indicating the values assigned to logical variables and the actual parameter values used for render instructions.

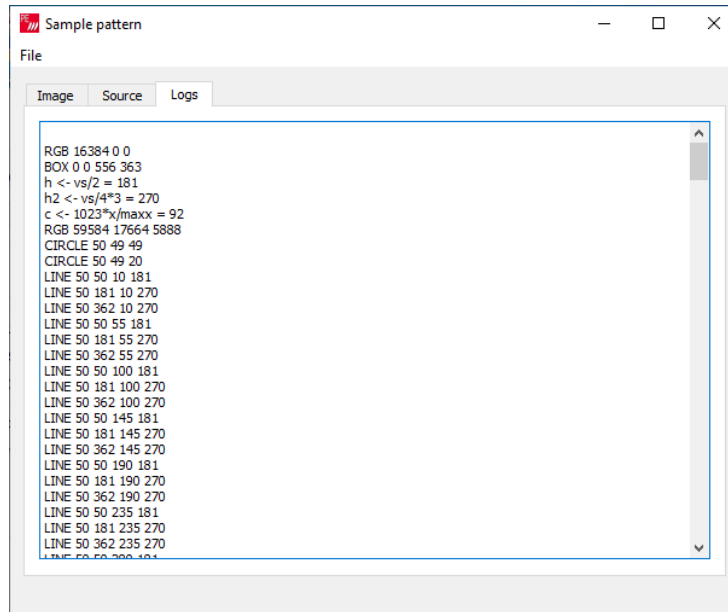

## Saving and Recalling the Script

In File pull-down menu the user can save his work.

*Open:* Open a VTP language script from PC

*Save Script:* Save the script currently in Source tab to PC

*Save Image:* Save a rendered pattern in PNG, BMP, JPG or PPM format

*Select Save Resolution:* Select from six common resolutions the size in which the pattern script will be rendered when saved.

## 10. IMAGE CONVERTER

Image Converter is a tool for converting images from one color format to another. This kind of conversion is typically needed when creating YCbCr test images from RGB bitmaps.

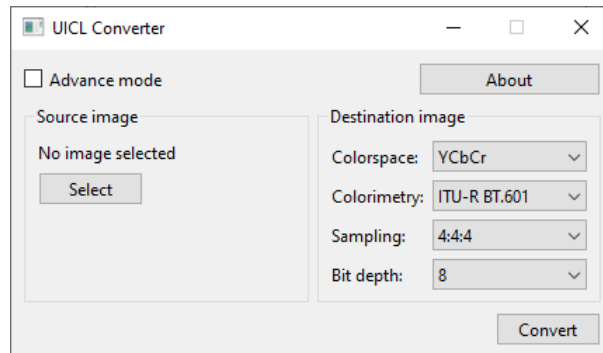
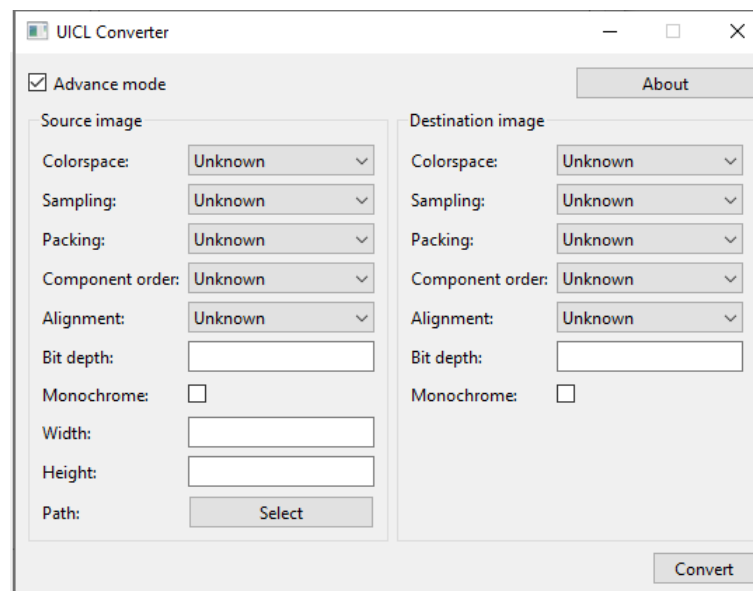

Image Converter has two operating modes: Standard mode and Advanced mode. In Standard mode typical Windows image file formats are used as Source image and the user sets basic color formats for the Destination image. In Advanced mode, the user is able to define the Source and Destination image parameters in detail.



Click **Select** to load the Source image. Click **Convert** to store the Destination image. File name for the Destination image is of form:

```
Source_image_1920x1080_8bits_yuv444_lsb.bin
```

<i>Source_image</i>	Name of the image file used as Source image
<i>1920x1080</i>	Resolution of the Source Image
<i>8bits</i>	Bit depth of the Destination image
<i>yuv444</i>	Color space and sampling of the Destination image
<i>lsb</i>	Data alignment of the Destination image

## APPENDIX A: PRODUCT SPECIFICATION

### UCD-301 Digital

Inputs	DisplayPort™ 1.4a compliant with HBR2 max bit rate HDMI 2.0 compliant
Max video mode	4096 × 2160 p60 input
Audio	LPCM, 2 – 8 channels, 44.1 to 192 kHz
Electrical Test	Verify electrical continuity of input signals
Computer interface	USB 3.0 and USB 2.0
Software	Windows 11, 10 and 8 compatible software driver. UCD Console application for Windows, Unigraf TSI API
Power supply	AC/DC Power supply (100 to 240 Vac 50/60 Hz input, +12 Vdc output)
Environmental	Operating temperature: 15 to 35 deg C Storage temperature: 0 to 50 deg C Humidity 30% to 70% RH, non-condensing
Mechanical Size	281 × 128 × 62 mm
Weight	0.9 kg w/o power supply

### UCD-323 HDDP

Inputs	DisplayPort™ 1.4a compliant with HBR2 max bit rate (DP in) HDMI 2.0 compliant (HDMI in)
Outputs	DisplayPort™ 1.4a compliant with HBR2 max bit rate (DP out) HDMI 2.0 compliant (HDMI out)
Max video mode	4096 × 2160 p60 input and output
Audio	LPCM, 2 – 8 channels, 44.1 to 192 kHz
Capture memory	Standard 2 GBytes, <i>UCD-323 HDDP 4K</i> 4 GBytes
Features	DisplayPort Tx supports Link Training with LT-Tunable PHY Repeaters
Computer interface	USB 3.0 and USB 2.0
Software	Windows 11, 10 and 8 compatible software driver. UCD Console application for Windows, Unigraf TSI API
Power supply	AC/DC Power supply (100 to 240 Vac 50/60 Hz input, +12 Vdc output)
Environmental	Operating temperature: 15 to 35 deg C Storage temperature: 0 to 50 deg C Humidity 30% to 70% RH, non-condensing
Mechanical Size	281 × 128 × 62 mm
Weight	0.9 kg w/o power supply

## UCD-323 Gen2

Inputs	DisplayPort™ 1.4a compliant with HBR2 max bit rate (DP in) HDMI 2.0 compliant (HDMI in)
Outputs	DisplayPort™ 1.4a compliant with HBR2 max bit rate (DP out) HDMI 2.0 compliant (HDMI out)
Max video mode	4096 × 2160 p60 input and output
Audio	LPCM, 2 – 8 channels, 44.1 to 192 kHz
Capture memory	Standard 4 GBytes
Features	DisplayPort Tx supports Link Training with LT-Tunable PHY Repeaters. Companion tool for automated PHY CTS through Unigraf TSI API.
Computer interface	USB 3.0 and USB 2.0
Software	Windows 11, 10 and 8 compatible software driver. UCD Console application for Windows, Unigraf TSI API
Power supply	AC/DC Power supply (100 to 240 Vac 50/60 Hz input, +12 Vdc output)
Environmental	Operating temperature: 15 to 35 deg C Storage temperature: 0 to 50 deg C Humidity 30% to 70% RH, non-condensing
Mechanical Size	281 × 128 × 62 mm
Weight	0.9 kg w/o power supply

## UCD-340

Test Connections	USB Type-C (Dual Role Port), USB Type-A (Device) pass-thru USB Type-B (Host) pass-thru External Power Source / Sink connector
DP Alt Mode	4096 × 2160 p60 input and output Up to HBR2 rate in up to 4 lanes Support HDCP 1.3 and 2.3
Audio	LPCM, 2 – 8 channels, 44.1 to 192 kHz
Capture memory	Standard 4 GBytes
USB Over USB-C	USB 3.1 Gen1 (5 Gbps) and USB 2.0 pass-thru
USB Power Delivery	Sink and source 5 V up to 3.0 A, up to 20 V / 5 A with external power test unit (Optional)
Electrical Test	Verify voltage current flow in USB Type-C interface signals (VBUS, GROUND, CC1/2, SBU1/2). (Optional)
Computer interface	USB 3.0 and USB 2.0
Software	Windows 11, 10 and 8 compatible software driver. UCD Console application for Windows, Unigraf TSI API
Power supply	AC/DC Power supply (100 to 240 Vac 50/60 Hz input, +12 Vdc output)
Environmental	Operating temperature: 15 to 35 deg C Storage temperature: 0 to 50 deg C Humidity 30% to 70% RH, non-condensing
Mechanical Size	281 × 128 × 62 mm
Weight	0.9 kg w/o power supply

All specifications are subject to change without notice.

# APPENDIX B: PRODUCT FEATURES

## UCD-301 and UCD-323

Interface Role / Product Option	Default	Console Pro	HDCP 2.3 support (Console Pro)	HDCP 2.3 CTS Sink / Source DUT	TSI Basic	TSI Advanced	Electrical Test	HDCP 2.3 support
<b>HDMI Reference Sink</b>								
Video status, preview and saving	•				▲			
Audio monitoring, graphical preview and saving	•				▲			
Link status	•				▲			
Link control		•				▲		
HPD status and control	•				▲			
EDID read and write		•				▲		
EDID Editor		•						
HDCP 1.4 status and control		•				▲		
HDCP 2.3 status and control			•					▲
Event Log		•						
Infoframe status		•				▲		
ARC (UCD-301)		•				▲		
Source DUT Testing		•				▲	▲	
Electrical Test (UCD-301)		•					▲	
<b>DP Reference Sink</b>								
Video status, preview and saving	•				▲			
Buffered capture		•						
Audio monitoring, graphical preview and saving	•				▲			
Link status	•				▲			
Link control		•				▲		
HPD status and control	•				▲			
DPCD editor		•						
Monitor InfoFrame Status (SDP)		•				▲		
EDID read and write		•				▲		
EDID / DisplayID Editor		•						
HDCP 1.3 status and control		•						
HDCP 2.3 status and control			•					▲
Event Log, AUX Analyzer		•						
Source DUT Testing (Link and CRC test)		•				▲		
Electrical Test UCD-301		•					▲	
HDCP 2.3 CTS for testing DP Source DUT				•				

\*) Separate licenses for testing Sink and Source DUT

## UCD-301 and UCD-323 (cont.)

Input /Output Role	Default	Console Pro	HDCP 2.3 support (Console Pro)	HDCP 2.3 CTS Sink / Source DUT	TSI Basic	TSI Advanced	HDCP 2.3 support
<b>HDMI Reference Source (UCD-323 only)</b>							
Video pattern generator (fixed patterns and timings)	•					▲	
Custom video patterns and timings		•					▲
Playback		•					▲
Audio Generator	•						
Link status	•						▲
Link control		•					▲
EDID read and write		•					▲
EDID Editor		•					
SCDC Editor		•					▲
Event Log		•					
Sink DUT Testing		•					
HDCP 1.4 status and control		•					▲
HDCP 2.3 status and control			•				
<b>DP Reference Source (UCD-323 only)</b>							
Video pattern generator (fixed patterns and timings)	•				▲		
Custom video patterns and timings		•				▲	
Audio generator	•						
Playback		•				▲	
Link status	•				▲		
Link control		•					
HPD status	•					▲	
EDID read and write		•				▲	
EDID / DisplayID Editor		•					
MST Feature (up to 2 streams)	•						
DPCD editor		•					
HDCP 1.3 status and control		•				▲	
HDCP 2.3 status and control			•				
Event Log, AUX Analyzer		•					
Sink DUT Testing		•					
HDCP 2.3 CTS for testing DP Sink DUT				•			

### UCD-301 and UCD-323 SW Product Options

Product	P/N	Product	P/N
UCD Console Pro for HDMI Reference Sink	MT6610	DP HDCP 2.3 CTS for testing Source DUT	MT6634
UCD Console Pro for DP Reference Sink	MT6611	DP HDCP 2.3 CTS for testing Sink DUT	MT6636
UCD Console Pro for HDMI Reference Source	MT6613	TSI SDK Advanced Test Set	MT6501
UCD Console Pro for DP Reference Source	MT6614	TSI SDK Adv. Test Set with HDCP 2.3 support	MT6516
HDCP 2.3 support	MT6504	TSI Electrical Test Set	MT6502



## UCD-340

Input /Output Role	UCD-340 Default	Console Pro	HDCP 2.3 support (Console Pro)	HDCP 2.3 CTS Sink / Source DUT	TSI Basic	TSI Advanced	HDCP 2.3 support
<b>DP Reference Sink</b>							
Video status, preview and saving	•				▲		
Buffered capture		•					
Audio monitoring, graphical preview and saving	•				▲		
Link status	•				▲		
Link control		•				▲	
HPD status and control	•				▲		
DPCD editor		•					
Monitor InfoFrame Status (SDP)		•				▲	
EDID read and write		•				▲	
EDID / DisplayID Editor		•					
HDCP 1.3 status and control		•					
HDCP 2.3 status and control			•				▲
Event Log, AUX Analyzer		•					
Source DUT Testing (Link and CRC test)		•				▲	
Electrical Test	•				▲		
HDCP 2.3 CTS for testing DP Source DUT				•			
<b>DP Reference Source</b>							
Video pattern generator (fixed patterns and timings)	•				▲		
Custom video patterns and timings		•				▲	
Audio generator	•						
Playback		•				▲	
Link status	•				▲		
Link control		•				▲	
HPD status	•					▲	
EDID read and write	•					▲	
EDID / DisplayID Editor		•					
DPCD editor		•					
HDCP 1.3 status and control		•				▲	
HDCP 2.3 status and control			•				▲
Event Log, AUX Analyzer		•					
Sink DUT Testing		•					
HDCP 2.3 CTS for testing DP Sink DUT				•			

## UCD-340 (cont.)

Input /Output Role	UCD-340 Default	Pro License	TSI Basic	TSI Advanced
<b>USB-C Modes Common</b>				
USB-C Data Role status & control	•		▲	
USB-C Power Role status & control	•		▲	
USB-C Vbus / CC / Vconn voltage / current monitoring	•		▲	
Power Delivery protocol monitoring		•		▲
Cable Info (E-marker details)		•		▲
Electrical cable flip test	•		▲	
Event Logger		•		
Support for USB-C Power for 5V/3A	•		▲	
Support for USB-C External Power Unit up to 20V/5A		•		▲
USBC Electrical Test option	•		▲	
<b>DP Alt Mode Common</b>				
USB-C DP ALT Mode status	•		▲	
USB-C DP ALT Mode control	•		▲	

### UCD-340 Product SW Options

Product	P/N
UCD Console Pro for Type-C DP Sink key	MT6640
UCD Console Pro for Type-C DP Source key	MT6641
HDCP 2.3 support	MT6504
DP HDCP 2.3 CTS for testing Source DUT	MT6634
DP HDCP 2.3 CTS for testing Sink DUT	MT6636
TSI SDK Advanced Test Set	MT6501

## APPENDIX C: PREDEFINED TIMINGS











Description	TSI*	HA	VA	HT	VT	HST	VST	HSYN	VSYN	FR	Pixel Clock (MHz)
CVT 640 x 480 @ 60Hz	0	640	480	800	525	144	35	96	2	60	25,20
DMT 800 x 600 @ 60Hz	1	800	600	1056	628	216	27	128	4	60	39,79
DMT 848 x 480 @ 60Hz	2	848	480	1088	517	224	31	112	8	60	33,75
DMT 1024 x 768 @ 60Hz	3	1024	768	1344	806	296	35	136	6	60	65,00
CTA 1280 x 720 @ 60Hz (VIC 4)	4	1280	720	1650	750	260	25	40	5	60	74,25
CVT 1280 x 768 @ 60Hz	5	1280	768	1440	790	112	19	32	7	60	68,26
DMT 1280 x 960 @ 60Hz	6	1280	768	1664	798	320	27	128	7	60	79,67
DMT 1280 x 800 @ 60Hz [RB1]	7	1280	800	1440	823	112	20	32	6	60	71,11
DMT 1280 x 800 @ 60Hz	8	1280	800	1680	831	328	28	128	6	60	83,76
DMT 1280 x 768 @ 60Hz	9	1280	960	1800	1000	424	39	112	3	60	108,00
DMT 1280 x 1024 @ 60Hz	10	1280	1024	1688	1066	360	41	112	3	60	107,96
DMT 1360 x 768 @ 60Hz	11	1360	768	1792	795	368	24	112	6	60	85,48
DMT 1400 x 1050 @ 60Hz	12	1400	1050	1560	1080	112	27	32	4	60	101,09
CVT 1600 x 1200 @ 60Hz [RB1]	13	1600	1200	1760	1235	112	32	32	4	60	130,42
DMT 1600 x 1200 @ 60Hz	14	1600	1200	2160	1250	496	49	192	3	60	162,00
DMT 1680 x 1050 @ 60Hz	15	1680	1050	1840	1080	112	27	32	6	60	119,23
DMT 1680 x 1050 @ 60Hz [RB1]	16	1680	1050	2240	1089	456	36	176	6	60	146,36
DMT 1792 x 1344 @ 60Hz	17	1792	1344	2448	1394	528	49	200	3	60	204,75
CVT 1920 x 1080 @ 30Hz [RB1]	18	1920	1080	2080	1096	112	13	32	5	30	68,39
CVT 1920 x 1080 @ 30Hz [RB2]	19	1920	1080	2000	1096	72	14	32	8	30	65,76
CTA 1920 x 1080 @ 30Hz (VIC 34)	20	1920	1080	2200	1125	192	41	44	5	30	74,25
CVT 1920 x 1080 @ 60Hz [RB1]	21	1920	1080	2080	1111	112	28	32	5	60	138,65
CVT 1920 x 1080 @ 60Hz [RB2]	22	1920	1080	2000	1111	72	14	32	8	60	133,32
CTA 1920 x 1080 @ 60Hz (VIC 16)	23	1920	1080	2200	1125	192	41	44	5	60	148,50
CVT 1920 x 1080 @ 120Hz [RB1]	24	1920	1080	2080	1144	112	61	32	5	120	285,54
CVT 1920 x 1080 @ 120Hz [RB2]	25	1920	1080	2000	1144	72	14	32	8	120	274,56
CTA 1920 x 1080 @ 120Hz (VIC 63)	26	1920	1080	2200	1125	192	41	44	5	120	297,00
DMT 1920 x 1440 @ 60Hz	27	1920	1440	2600	1500	552	59	208	3	60	234,00
CVT 2048 x 1536 @ 60Hz	28	2048	1536	2208	1580	112	41	32	4	60	209,32
CVT 2560 x 1440 @ 60Hz	29	2560	1440	2720	1481	112	38	32	5	60	241,70
CVT 2560 x 1080 @ 60Hz	30	2560	1080	3424	1120	704	37	272	10	60	230,09
CVT 2560 x 1080 @ 60Hz [RB1]	31	2560	1080	2720	1111	112	28	32	10	60	181,32
DMT 2560 x 1600 @ 60Hz	32	2560	1600	3504	1658	752	55	280	6	60	348,58
DMT 2560 x 1600 @ 60Hz [RB1]	33	2560	1600	2720	1646	112	43	32	6	60	268,63
UG 2880 x 1440 @ 60Hz	34	2880	1440	2976	1456	48	8	8	1	60	259,98
CVT 4096 x 2160 @ 60Hz	35	4096	2160	4176	2222	72	14	32	8	60	556,74
CVT 3840 x 2160 @ 30Hz [RB1]	36	3840	2160	4000	2191	112	28	32	5	30	262,92
CVT 3840 x 2160 @ 30Hz [RB2]	37	3840	2160	3920	2191	72	14	32	8	30	257,66
CTA 3840 x 2160 @ 30Hz (VIC 100)	38	3840	2160	4400	2250	384	82	88	10	30	297,00
CTA 3840 x 2160 @ 50Hz (VIC 96)	39	3840	2160	5280	2250	384	82	88	10	50	594,00
CTA 4096 x 2160 @ 50Hz (VIC 101)	40	4096	2160	5280	2250	216	82	88	10	50	594,00
CVT 3840 x 2160 @ 60Hz [RB1]	41	3840	2160	4000	2222	112	59	32	5	60	533,28
CVT 3840 x 2160 @ 60Hz [RB2]	42	3840	2160	3920	2222	72	14	32	8	60	522,61
CTA 3840 x 2160 @ 60Hz (VIC 97)	43	3840	2160	4400	2250	384	82	88	10	60	594,00
CTA 4096 x 2160 @ 60Hz (VIC 102)	44	4096	2160	4400	2250	216	82	88	10	60	594,00

\*) TSI Timing ID





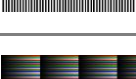
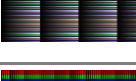
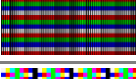















CVT: Coordinated Video Timings (CVT; VESA-2013-3 v1. 2); DMT: VESA and Industry Standards and Guidelines for Computer Display Monitor Timings; CTA: A DTV Profile for Uncompressed High Speed Digital Interfaces (CTA-861-H); UG: Unigraf proprietary timing

## APPENDIX D: PREDEFINED PATTERNS























### Fixed Patterns

Selection	Pattern	Description
Disabled		The links are activated but no video data transferred
Color Bar		100% intensity color bars of all primaries and mixed combinations.
Chessboard		8 by 8 chessboard with black (0%) and 100% intensity white
Solid Black		0% luminance
Solid White		100% white
Solid Red		100% red
Solid Green		100% green
Solid Blue		100% blue
White V-Strips		Vertical stripes of black (0%) and white (100%). Parameters set the widths of the black and white stripes in pixels respectively. Default black / white = 20 / 20 pixels. Parameter range 1 to 1000.
RGB Wide Strips		16 pixels high horizontal red, green, blue and white stripes. Intensity is increased from 0 to 100% with steps defined by the given parameter (Color Step = cs) and selected color. (step = cs*color_depth/256). "n" range 0 to 5000 (default 100).
Color Ramp		Color Ramp test pattern defined by VESA DisplayPort Link Layer Compliance Test Specification.
Color Square		Color Square test pattern defined by VESA DisplayPort Link Layer Compliance Test Specification. Color mode can be selected between RGB, YCbCr 4:4:4, 4:2:2, 4:2:0 (ITU Rec 601 / 709)
Motion Pattern		Horizontally moving color bar pattern. The pattern is shifted to left one pixel in each frame in a sequence. The length of the sequence is defined with parameter. Range 0 to 34 (default is 20)
Square Window		100% intensity white square horizontally and vertically centered. Height and width defined by parameter as the percentage of height and width of the frame (default 30).



















## Extended Patterns

Selection	Icon	Description
Select Image		Custom image uploaded by the user. Click on Select ... to browse.
Select DSC Image		Custom DSC compressed image file uploaded by the user. Click on Select ... to browse.
Unigraf PM5544		Vpattern vector pattern based on PM5544
Color Web		Vpattern vector pattern.
Chinese Town Full HD		JPG Bitmap image (1920 x 1080 px)
UG-2111 HLG Narrow		Software generated pattern. HLG Narrow dynamic range.
UG-2111 PQ Narrow		Software generated pattern. PQ Narrow dynamic range.
UG-2111 PQ Full		Software generated pattern. PQ Full dynamic range.
Multi		Vpattern vector pattern. Multi-purpose pattern w square grid, cross-grids, 1x1 cross-hatches, circles, and color bars
SMPTE RP-133		Vpattern vector pattern based on SMPTE RP-133
SMPTE 303M		Vpattern vector pattern. SMPTE 303M; Full Range; RGB values before gamma correction based on D65 and PAL primaries
Blue		Vpattern vector pattern. 100% Blue
CirclesW		Vpattern vector pattern. Concentric circles
Complex		Vpattern vector pattern. Complex Pattern w 64 steps
Green		Vpattern vector pattern. 100% Green
Hor1W-Even		Vpattern vector pattern. Horizontal 1 px wide White bars in even rows
Hor1W-Odd		Vpattern vector pattern. Horizontal 1 px wide White bars in odd rows
Hor4W		Vpattern vector pattern. Horizontal 4 px high White bars
Hor10W		Vpattern vector pattern. Horizontal 10 px high White bars
Hor-10xB		Vpattern vector pattern. 10 pcs horizontal Blue bars
Hor-10G		Vpattern vector pattern. 10 pcs horizontal Green bars











## Extended Patterns (contd.)

Selection	Icon	Description
Hor-10xR		Vpattern vector pattern. 10 pcs horizontal Red bars
Hor-10xW		Vpattern vector pattern. 10 pcs horizontal White bars
HorRainbow-1024		Vpattern vector pattern. Horizontal Rainbow Ramps 1024 steps
HorRGBW-1024		Vpattern vector pattern. Horizontal RGBW Ramps 1024 steps
HorScale9		Vpattern vector pattern. Nine Horizontal Color Ramps
HorScaleW-64		Vpattern vector pattern. Horizontal White ramp 64 steps
HorScaleW-128		Vpattern vector pattern. Horizontal White ramp 128 steps
HorScaleW-X2		Vpattern vector pattern. Horizontal White ramp w edges 128 steps
InnerBox-BKtoB		Vpattern vector pattern. InnerBox pattern from Black to Blue
InnerBox-BKtoG		Vpattern vector pattern. InnerBox pattern from Black to Green
InnerBox-BKtoR		Vpattern vector pattern. InnerBox pattern from Black to Red
InnerBox-BKtoW		Vpattern vector pattern. InnerBox pattern from Black to White
InnerBoxMIX		Vpattern vector pattern. InnerBox pattern mixed hues.
InnerBox-RtoB		Vpattern vector pattern. InnerBox pattern from Red to Blue
Red		Vpattern vector pattern. 100% Red
Ver1W-Even		Vpattern vector pattern. Vertical 1 px wide White bars in even columns
Ver1W-Odd		Vpattern vector pattern. Vertical 1 px wide White bars in odd columns
Ver4W		Vpattern vector pattern. Vertical 4 px wide White bars
Ver10W		Vpattern vector pattern. Vertical 10 px wide White bars
Ver-10xG		Vpattern vector pattern. 10 pcs Vertical Blue bars
Ver-10xR		Vpattern vector pattern. 10 pcs Vertical Blue bars
Ver-10xB		Vpattern vector pattern. 10 pcs Vertical Blue bars
Ver-10xW		Vpattern vector pattern. 10 pcs Vertical Blue bars

## Extended Patterns (contd.)

Selection	Icon	Description
VerBars75%		Vpattern vector pattern. Vertical 75% intensity Color bars
VerBars100%		Vpattern vector pattern. Vertical 100% intensity Color bars
VerRGBW-1024		Vpattern vector pattern. Vertical RGBW Ramps 1024 steps
X-HatchBK-C		Vpattern vector pattern. Black 16 x12 Grid w Circle on White background
X-HatchW		White 16 x12 Grid on Black background
X-HatchW-C		White 16 x12 Grid w Circle on Black background
X-HatchW-CC		Vpattern vector pattern. White 16 x12 Grid w Ellipses, Circle and 100% color bars
Gray Box 10		China 5.6 White Window 10%
Gray Box 20		China 5.6 White Window 20%
Gray Box 30		China 5.6 White Window 30%
Gray Box 40		China 5.6 White Window 40%
Gray Box 50		China 5.6 White Window 50%
Gray Box 60		China 5.6 White Window 60%
Gray Box 70		China 5.6 White Window 70%
Gray Box 80		China 5.6 White Window 80%
Gray Box 90		China 5.6 White Window 90%
Gray Box 100		China 5.6 White Window 100%
8 Level Gray		China 5.5 Ultimate 8 Level Grayscale

## Extended Patterns (contd.)

Selection	Icon	Description
Black'n'White Window HDTV		China 5.8 Black and White Window(FOR HDTV)
Black'n'White Window SDTV		China 5.8 Black and White Window(FOR SDTV)
Black Line HDTV		China 5.10 Black Line
Black Line SDTV		China 5.10 Black Line SDTV
Black Window		China 5.7 Black Window
Check Board		China 5.9 Check Board
Line'n'Window		China 5.11 Line and Window
Narrow White Window		China 5.19 Narrow White Window
Single Dot		China Single Dot
White Line HDTV		5.10 White Line for HDTV
White Line SDTV		5.10 White Line for SDTV

More test patterns can be downloaded e.g. from [www.icdm-sid.org/downloads/testpatterns.html](http://www.icdm-sid.org/downloads/testpatterns.html).



# APPENDIX E: SINK AND SOURCE DUT TESTS

Source DUT Testing		Pro License	DP HDCP 2.3 CTS*	Electrical Testing
HDCP 2.3 CTS 1A Test Set DP RX (UCD-301, UCD-323, UCD-340)	HCDP2.3 CTS 1A-01 – HCDP2.3 CTS 1A-12		•	
HDCP 2.3 CTS 1B Test Set DP RX (UCD-301, UCD-323, UCD-340)	HCDP2.3 CTS 1B-01 – HCDP2.3 CTS 1B-10		•	
Audio Test Set (UCD-301, UCD-323, UCD-340)	Validate audio signal frequency and glitch-free audio reproduction	•		
CEC functional Test Set HDMI RX (UCD-301, UCD-323)	CEC functional test, CEC PHY Addr test, CEC Complete test, CEC Wake up test, CEC Standby test	•		
CRC based Video Test Set (UCD-301, UCD-323, UCD-340)	CRC based single frame reference video test; CRC based single frame stability test; CRC based sequence of frames reference video test	•		
Electrical Test Set HDMI RX (UCD-301)	Power test; TMDS test; HPD test; DDC and CEC test			•
Electrical Test Set DP RX (UCD-301, UCD-340)	HPD test; Main Link test; AUX test			•
Link Config Tests (UCD-301, UCD-323, UCD-340)	Link Training at All Supported Lane Counts and Link Rates	•		
Pixel Level Video Tests (UCD-301, UCD-323, UCD-340)	Compare a defined number of captured frames to a single reference frame	•		
USBC Electrical Test Set (UCD-340)	Up Face Port CC and VCONN test; AUX (SBU) lines test; DUT as Power Sink; DUT as Power Source			•
VRR Source DUT Tests (HDMI RX) (UCD-323, UCD-301)	VRR static test; QMS Test; VRR Dynamic test	•		

\*) Separate licenses for testing Sink and Source DUT

Sink DUT Testing		Pro License	DP HDCP 2.3 CTS*	Electrical Testing
HDCP 2.3 CTS 2C Test Set DP TX (UCD-323, UCD-340)	HCDP2.3 CTS 2C-01 – HCDP2.3 CTS 2C-06		•	
USBC Electrical Test Set (UCD-340)	Up Face Port CC and VCONN test; AUX (SBU) lines test; DUT as Power Sink; DUT as Power Source			•
VRR Sink DUT Tests (HDMI TX) (UCD-323)	VRR static test; QMS Test; VRR Dynamic test	•		

\*) Separate licenses for testing Sink and Source DUT

## DP Compliance Tests

Role:	Product:
DP Reference Sink (DP RX)	UCD-301, UCD-323, UCD-340
DP Reference Source (DP TX)	UCD-323, UCD-340

Compliance test capability is a license enabled add-on to UCD Console.

The tests are included in the GUI software, license codes enable the tests for use. Please refer to *Appendix B Licensing* for details. The list of compliance tests that UCD Console supports, please refer to document *DP-CTS-Tool-Options-for-Unigraf-UCD-3XX.pdf*. The document can be downloaded in Unigraf Document Center at <https://www.unigraf.fi/documents/>.

If you have any additional questions, please contact Unigraf or your local representative.

Compliance tests (CTS Tests) are part of tests included in **Source DUT Testing** tab of **DP RX** and **Sink DUT Testing** tab of **DP TX**.

The tests cases are divided to test categories as described in *Appendix E* of this document. Test categories are placed in sub-tabs. Test category tabs are enabled base on licenses present. Please refer to chapter 3 *License Manager* earlier in this document.

### Test Parameters

Before running the tests, capabilities of the DUT have to be defined for the test engine. Each test category has its dedicated test parameter dialog. Click **Configure** in *Source DUT Testing* or *Sink DUT Testing* tab to open the parameter dialog.

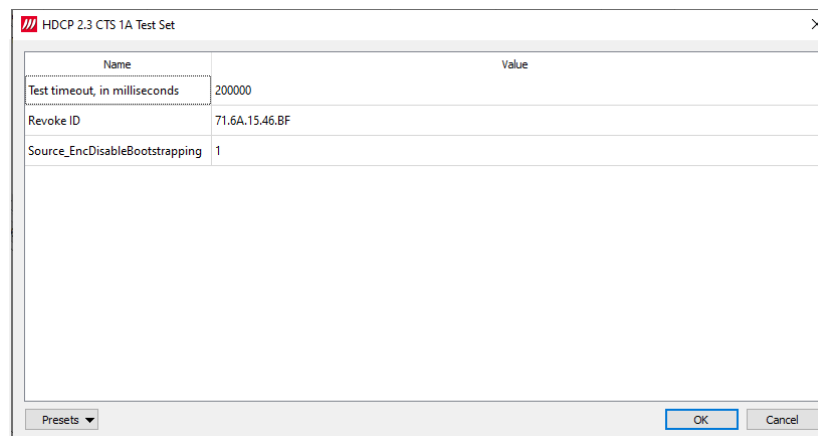

For a detailed description of capabilities listed on the tab please refer to *Chapter 3 Compliance Test Operation* of document *VESA DisplayPort v1.4a Link Layer Compliance Test Specification*.

---

**Note:** Please make sure that the capability tables are completed before running the tests. The result of the test might be misleading if the DUT capabilities and the table do not match.

---

### Saving Test Parameters

Test parameters can be saved for later use in two ways: internally or externally in a file.

In *parameter dialog* the parameter set can be saved as an internal **Preset**.

## Running CTS Tests

Source DUT Testing and Sink DUT Testing tabs include the tests enabled with the set of licenses present in UCD Console grouped in test set tabs. In tabs the tests are listed by the test name and reference number as in applicable compliance test specification. UCD firmware implements the test according to the test specification.

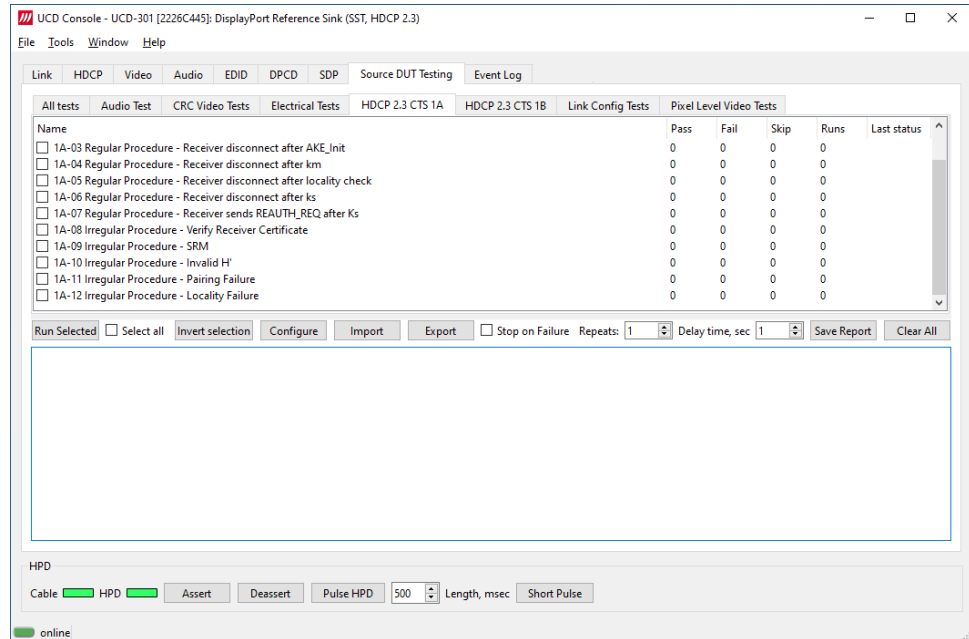

For running a test, select it and click **Run selected**. For selecting multiple consecutive tests in the list hold down the **Shift** key of your keyboard while selecting the tests. For selecting multiple individual tests hold down the **Ctrl** key in your keyboard while selecting.

Test flow parameters like **Test timeout** and **Test cycle delay** can be defined in *Test Parameter* dialog launched by clicking **Configure**.

<b>Run Selected</b>	Click to start selected tests. By clicking <i>Abort</i> the sequence is stopped.
<b>Select all:</b>	Select all tests in the selected tab.
<b>Invert selection</b>	Invert selection of tests selected. <b>Hint:</b> To clear all selections, click <i>Select all</i> and then <i>Invert selection</i> .
<b>Configure</b>	Clicking opens a dialog for defining the test parameters for that set. Please refer to <i>Test Parameters</i> below for description.
<b>Import:</b>	Load saved test parameter files (*.td or *.json).
<b>Export:</b>	Save test parameters for later use or for use in test automation. For saving parameters for later use in UCD Console, either format can be used. For saving parameters for TSI scripting, please use *.td files. For use with Python applications, please use *.json files.
<b>Stop on Failure:</b>	Stops execution of the selected tests if one of the tests fail
<b>Repeats:</b>	Repeat the selected test several times. When repeating a sequence of tests, all selected tests are performed in each repetition. E.g., when you repeat tests 1, 2 and 3 two times, the sequence is: 1, 2, 3, 1, 2, 3.
<b>Delay time</b>	Delay in seconds between individual tests.
<b>Save Report:</b>	Click to generate a HTML report file for sharing the results with other parties for <i>viewing</i> without UCD Console.
<b>Clear Log</b>	Clear the test log and the results matrix

## Saving Test Parameters

Test parameters can be saved in various ways.

- Export parameters in *Sink DUT Testing* tab to a \*.td file for later use in UCD Console or with TSI scripting or sharing.
- Export parameters in *Sink DUT Testing* tab to a \*.json file for later use in UCD Console or with Python applications or sharing.
- Save parameters in *Configure* dialog as Presets to be later used in Console. Please find a description below.

## Presets

In all *Configure* dialogs the selected parameters can be saved as Presets. Please click **Presets...** to save or recall a configuration.

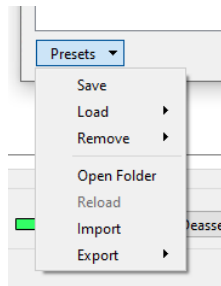

## Evaluating CTS Test Results

The test procedure advancement can be monitored in the *Test Log* panel. It describes the steps of each individual test in the way defined in the corresponding VESA Compliance Test Specification. Please use the Status Log and Specification side by side when interpreting the results.

At the completion of each test the result of the test is indicated in the matrix on the right hand side of the test panel. For each test the matrix lists the number of occurrences of each result and the number of tries performed.

Name	Pass	Fail	Skip	Runs	Last status
<input checked="" type="checkbox"/> 2C-01 Regular Procedure - With transmitter	1	0	0	1	Pass
<input checked="" type="checkbox"/> 2C-02 Irregular Procedure - New Authentication after AKE_Init	1	0	0	1	Pass
<input checked="" type="checkbox"/> 2C-03 Irregular Procedure - New Authentication during Locality Check	1	0	0	1	Pass
<input type="checkbox"/> 2C-04 Irregular Procedure - New Authentication after SKE_Send_Eks	0	0	0	0	
<input type="checkbox"/> 2C-05 Irregular Procedure - New Authentication during Link Synchronization	0	0	0	0	

```

0000.711.624: [TE-Src] H* is equal to H
0000.912.948: [TE-Src] DUT didn't set PAIRING bit
0000.913.117: [TE-Src] [Locality Check]
0000.913.244: [TE-Src] STEP 2C-01-8
0000.913.661: [TE-Src] Sends LC_Init message
0000.930.889: [TE-Src] LC_Send_L_prime message available within 16ms
0000.931.078: [TE-Src] L* matches L
0000.931.244: [TE-Src] [Session Key Exchange]
0000.931.368: [TE-Src] STEP 2C-01-09
0000.932.107: [TE-Src] Transmits SKE_Send_Eks message
0000.932.428: [TE-Src] Writes Type value
0001.933.250: [TE-Src] Enables HDCP Encryption within 200ms after SKE_Send_Eks
0001.983.128: [TE-Src] Transmits visible test pattern to DUT
0001.983.301: [TE-Src] DUT completes the authentication process
0001.983.556: Test PASSED: "2C-03 Irregular Procedure - New Authentication during Locality Check"
Test Complete
Tests execution finished.
    
```

## Test Report

Results of the test can be saved as a report in HTML format. The report file can be viewed with any HTML browser. The report has built-in views for Report Summary, Test Summary, and individual Test Logs.

The user can add details of the DUT, test situation and other remarks to the report.

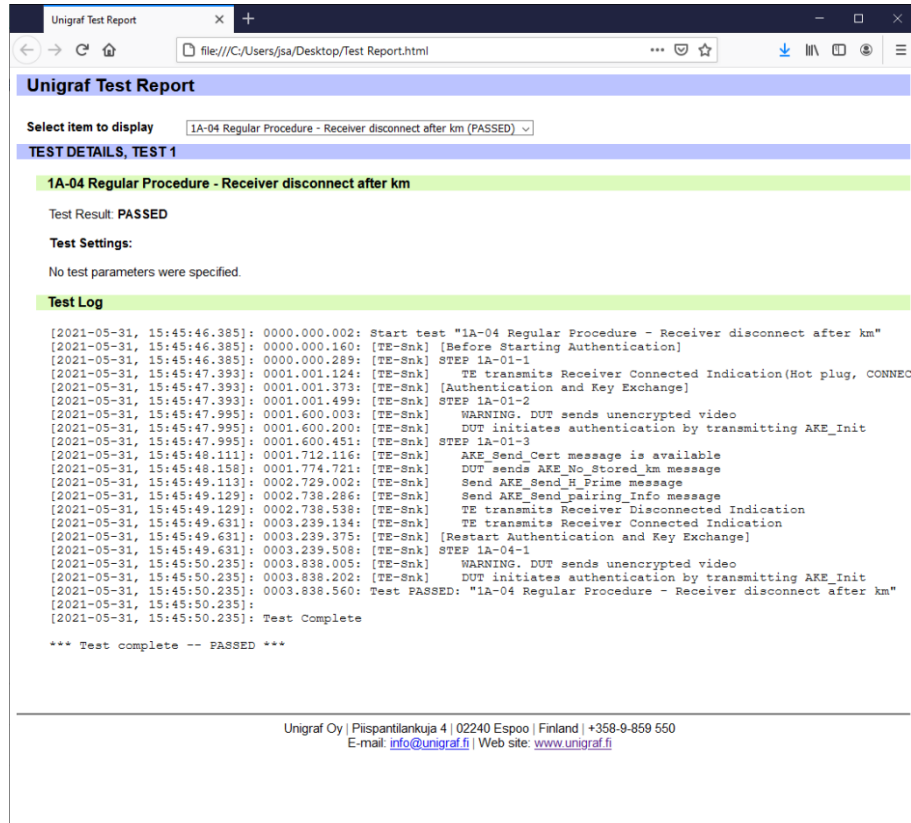

## Audio Test Set – DP Rx, HDMI Rx

Role:	Product:
DP Reference Sink (DP RX)	UCD-301, UCD-323
HDMI Reference Sink (HDMI RX)	UCD-301, UCD-323
DP Alt Mode Reference Sink (DP RX)	UCD-340

### Validate audio signal frequency and glitch-free audio reproduction

Perform frequency check on the digital audio content and verify the content to be glitch-free. This test assumes that a pure sine-wave audio signal content is being transmitted to the test equipment.

The test will first capture minimum of one second of audio content. The audio is then analyzed in two stages.

First, the power spectrum is calculated, and the highest peak must be within the defined window. Resolution of the peak frequency check is better than  $\pm 1$  Hz.

In the second stage, received audio is checked for random glitches, such as dropped or duplicated samples.

The test is considered passed if power of audio content spectrum has its maximum within the defined window, and the number of detected audio glitches does not exceed programmed limit.

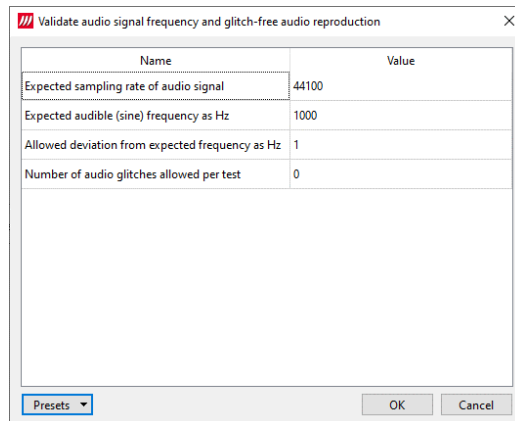

### Parameters in use

- Expected sampling rate of audio signal (default 44 100 s/sec)
- Expected audible (sine) frequency in Hz (default 1000 Hz)
- Allowed deviation from expected frequency in Hz (default 1 Hz)
- Number of audio glitches allowed per test (default 0)

## CEC Functional Test Set – HDMI Rx

Role:

HDMI Reference Sink (HDMI RX)

Product:

UCD-301, UCD-323

### CEC Functional Test

TE verifies that source DUT correctly handles an HPD event, reads the sink EDID and broadcasts a CEC “Report physical address” message.

First, the TE allocates the physical address provided as a parameter and issues an HPD pulse simulating cable detach/attach. After that the TE waits for DUT source to broadcast the CEC “Report physical address” message.

The test is considered passed if DUT sends a correct “Report physical address” message.

---

**Note:** The default physical address in UCD-300 EDID is 1:0:0:0. In order to simulate a change in the address, please use another address range

---



---

**Note:** As a side effect, the CEC will also verify functionality of HPD and EDID reading if the test passes.

---

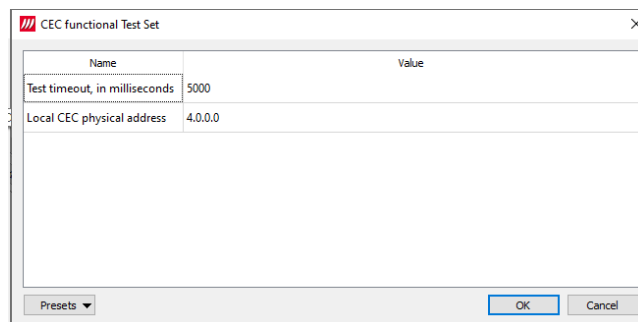

#### Parameters in use

- Test Timeout (default 5 000 ms)
- Local CEC physical address (default 4.0.0.0)

### CEC PHY Addr test

TBD

### CEC Complete test

TBD

### CEC Wake up test

TBD

### CEC Standby test

TBD

## CRC Based Video Test Set – HDMI Rx, DP Rx

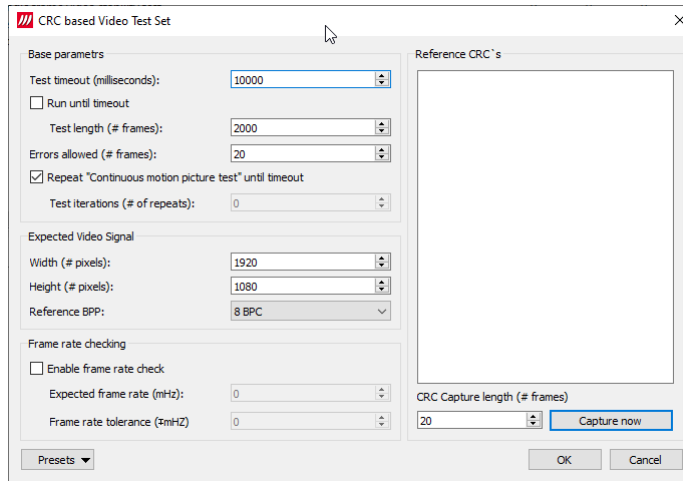

Role:	Product:
HDMI Reference Sink (HDMI RX)	UCD-301, UCD-323
DP Reference Sink (DP RX)	UCD-301, UCD-323
DP Alt Mode Reference Sink (DP RX)	UCD-340
Test timeout:	If enabled test will abort when the time has elapsed
Run until timeout:	Enable "Test timeout"
Test length (# frames):	Number of captured frames to test
Errors allowed (# frames):	Number of failing frames allowed before test is Fails
Repeat "Continuous motion test" until timeout:	Repeat test sequence until the timeout set
Test iterations (# of repeats):	Repeat the sequence
Expected video signal	Format of the signal expected
Enable frame rate check:	Verify stability of the video signal
CRC capture length (# frames):	Number of frames stored as reference
Capture now:	Capture reference frames for the test
Folder to save failed images:	PC folder where failed frames are stored.
Maximum number of exported frames:	Maximum number of failed frames stored to PC
Export to ppm format	Export the failed frames as .ppm bitmap files
Presets:	Store and recall settings



### CRC Based Single Reference Frame Video Test

The test compares captured frames to a provided reference.

TE compares the video mode (Frame Width, Height, BPP and optionally Frame rate) to provided parameters and after that captures frames and compares the CRC (check sum) of their three color components to the provided reference until the number of bad frame limit provided is detected or the provided total number of frames is reached.

The test is judged FAIL if video mode does not match, or the number of bad frames is exceeded.

The test optionally captures the failed frames as bitmap images and stores them into the hard disc.

#### Parameters in use

- Test Timeout (default 100 000 ms)
- Total number of frames (default 2 000 ms)
- Number of bad frames allowed (default 2)
- Reference width (default 1920)
- Reference height (default 1080)
- Reference BPP (default 24)
- Expected frame rate (mHz)
- Frame rate tolerance (mHz)
- Reference CRCs (R, G, B)

### CRC Based Single Frame Video Stability Test

The test verifies that the captured video is stable.

TE captures a frame and sets the CRC of its color components as reference. After that TE captures frames and compares their CRC (check sum) to the reference until the number of bad frame limit provided is detected or the provided total number of frames is reached.

The test is judged FAIL if the number of bad frames is exceeded.

The test optionally captures the failed frames as bitmap images and stores them into the hard disc.

#### Parameters in use

- Test Timeout (default 100 000 ms)
- Total number of frames (default 2 000 ms)
- Number of bad frames allowed (default 2)

### CRC Based Sequence of Reference Frames Test

The verifies that a sequence of frames is captured in the right order.

TE compares the video mode (frame Width, Height, BPP and optionally Frame rate) to provided parameters. After that captures frames to find a frame with matching CRC (check sum) of their three color components to the first provided reference. After the first matching CRC is found it compares the CRC of the following frames until the Number of frames tested parameter is reached.

The test is judged FAIL if video mode does not match, the first frame in the list is not found or the CRC of the following frames do not match the provided list.

The test optionally captures the failed frames as bitmap images and stores them into the hard disc.

#### Parameters in use

- Test Timeout (default 100 000 ms)
- Number of frames to be tested (default 20)
- Reference width (default 1920)
- Reference height (default 1080)
- Reference BPP (default 24)
- Expected frame rate (mHz)
- Frame rate tolerance (mHz)
- Reference CRCs (R, G, B)

---

**Note:** Please note that in order for the TE to maintain the sequence, all CRCs in the reference frame list should be different.

---

### CRC Based Continuous Sequence of Reference Frames Test

The verifies that a sequence of frames is captured in the right order many times repeatedly.

TE compares the video mode (frame Width, Height, BPP and optionally Frame rate and Color format) to provided parameters. After that captures frames to find a frame with matching CRC (check sum) of their three color components to the first provided reference. After the first matching CRC is found it compares the CRC of the following frames until the Number of frames tested parameter is reached. After that it resets the list and starts from the first CRC. The list is repeated until timeout or until the provided number of repetitions is reached.

The test is judged FAIL if video mode does not match, the first frame in the list is not found or the CRC of the following frames do not match the provided list.

The test optionally captures the failed frames as bitmap images and stores them into the hard disc.

#### Parameters in use

- Test Timeout (default 100 000 ms)
- Number of frames to be tested (default 20)
- Number of iterations
- Reference width (default 1920)
- Reference height (default 1080)
- Reference BPP (default 24)
- Expected frame rate (mHz)
- Frame rate tolerance (mHz)
- Expected color format
- Reference CRCs (R, G, B)

---

**Note:** Please note that in order for the TE to maintain the sequence, all CRCs in the reference frame list should be different.

---

## Electrical Test Set – HDMI Rx

Role:	Product:
HDMI Reference Sink (HDMI RX)	UCD-301

Electrical Tests verify the continuity of the interface signals and the voltage levels applied by the driving electronics.

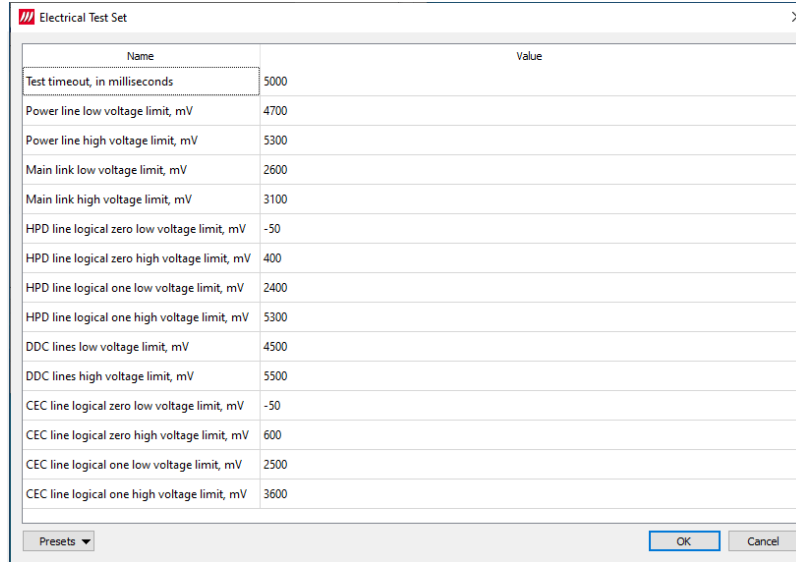

### Power Test

*Power Test* verifies the voltage level on the +5 V power line (Pin 18) of the DUT source. The accepted value in HDMI specification is 4.7 V to 5.3 V on the sink side connector. (Called “TP2” in the HDMI specification).

The test will measure the power line voltage using two loads: 0 mA and 55 mA. The latter is the test setup in HDMI CTS specification (HDMI CTS 1.4b: Test ID 7-11: +5V Power). The test will fail if voltage level on the power line is below or above the voltage range set by the parameters.

#### Parameters in use

- Test Timeout (default 5 000 ms)
- Power line low voltage limit (default 4 700 mV)
- Power line high voltage limit (default 5 300 mV)

## TMDS Test

*TMDS Test* verifies average voltage levels on TMDS signal lines (8 lines: CLK+/-, D0+/- D1+/- and D2+/-). The positive and negative lines of the TMDS differential pair are measured separately.

TMDS uses DC balanced signaling. Sink pulls the lines up to 3.3 V (AVcc) and source applies the TMDS signal by pulling the line down to ground. On an active TMDS line average voltage level is half of the voltage swing below AVcc ( $AV_{cc} - V_{swing}/2$ ). By default, 2.6 V to 3.1 V.

TMDS line voltages outside of the above range might indicate an abnormal situation like short circuit of two TMDS lines, short to ground, open circuit or a broken output driver.

If the measured values fall outside the criteria set by the parameters, test result is FAIL.

---

**Note:** Fail criteria for each test set-up should be considered separately depending on the source DUT and test cable configuration.

---

### Parameters in use

- Test Timeout (default 5 000 ms)
- Main link low voltage limit (default 2 600 mV)
- Main link high voltage limit (default 3 100 mV)

## HPD Test

*HPD Test* verifies HPD line (pin 19) for short circuits to power or ground.

The test runs in two steps:

Step 1. HPD line is driven to logical low state and after a delay voltage level is measured. If the measured value is outside the limits set by the parameters for “zero” voltage minimum and maximum the test result is FAIL. The judgement is “Short to ground” or “Short to power” depending if the measured value is below the allowed window, or above it.

Step 2. HPD line is driven to logical high state and after a delay voltage level is measured. If the measured value is outside the limits set by the parameters for “one” voltage minimum and maximum the test result is FAIL. The judgement is “Short to ground” or “Short to power” depending if the measured value is below the allowed window, or above it.

### Parameters in use

- Test Timeout (default 5 000 ms)
- HPD line logical zero low voltage limit (default -50 mV)
- HPD line logical zero high voltage limit (default 400 mV)
- HPD line logical one low voltage limit (default 2 400 mV)
- HPD line logical one high voltage limit (default 5 300 mV)

## DDC and CEC Test

*DDC and CEC Test* verifies voltage level of SCL (pin 15), SDA (pin 15) and CEC (pin 13) lines. HPD signal is driven low to de-activate any transmission in the tested lines. After a delay of 100 ms voltage level is measured in the three signal lines.

If the measured voltage levels are outside the parameter limits, the test result is FAIL.

### Parameters in use

- Test Timeout (default 5 000 ms)
- DDC lines low voltage limit (default 4 500 mV)
- DDC lines high voltage limit (default 5 500 mV)
- CEC line logical zero low voltage limit (default -50 mV)
- CEC line logical zero high voltage limit (default 600 mV)
- CEC line logical one low voltage limit (default 2 500 mV)
- CEC line logical one low voltage limit (default 3 600 mV)

## Electrical Test Set – DP Rx

Role:	Product:
DP Reference Sink (DP RX)	UCD-301
DP Alt Mode reference Sink (DP RX)	UCD-340 with Unigraf Electrical Test Cable

Electrical Tests verify the continuity of the interface signals and the voltage levels applied by the driving electronics.

### HPD Test

*HPD Test* verifies HPD line for short circuits into power or ground lines.

The test runs in two steps:

Step 1. HPD line is asserted to logical high state and after a delay voltage level is measured. If the measured value is outside the limits set by the parameters for “one” voltage minimum and maximum the test result is FAIL. The judgement is “Short to ground” or “Short to power” depending, if the measured value is below the allowed window, or above it.

Step 2. HPD line is de-asserted to logical low state and after a delay voltage level is measured. If the measured value is outside the limits set by the parameters for “zero” voltage minimum and maximum the test result is FAIL. The judgement is “Short to ground” or “Short to power” depending, if the measured value is below the allowed window, or above it.

#### Parameters in use

- Test Timeout (default 5 000 ms)
- HPD line logical zero low voltage limit (default -100 mV)
- HPD line logical zero high voltage limit (default 799 mV)
- HPD line logical one low voltage limit (default 2 000 mV)
- HPD line logical one high voltage limit (default 3 600 mV)

### Main Link Test

The test utilizes a dedicated microchip to determine the power of DP Main Link input signal. The test verifies that the measured values lie within the window defined by provided parameters.

The measured values provide a relative voltage value that depends on the signal waveform and selected pre-emphasis and voltage swing. The values do not represent any absolute value, e.g., input signal voltage level.

“No signal” level is initially set to 2.3V. Note that even a disconnected line will give a relatively high value. Good signal levels are expected to be within range 2.6 V to 4.0 V. The allowed voltage window should be set separately for each device model after testing of several units.

Measured values are expected to be close to each other within a differential pair. Also, all main link differential pair measurements should produce a value close to each other if link training result is the same for all pairs.

Measurement results are given in volt, but this is only the voltage level of power measurement circuitry output and does not relate to the actual input signal. The positive and negative lines of main link differential pairs are measured separately.

---

**Note:** The measured values provide a relative voltage value that depends on the signal waveform and selected pre-emphasis and voltage swing. The values do not represent any absolute value, e.g. input signal voltage level.

---

### Parameters in use

- Test Timeout (default 5 000 ms)
- Main link low voltage limit (default 2 600 mV)
- Main link high voltage limit (default 4 000 mV)
- Maximum lanes count supported by DUT (default 0)
- Maximum data rate supported by DUT in 0.27 Gbps (default 0)

### **AUX Test**

The test verifies voltage levels on AUX lines, and AUX connectivity to DUT.

The test verifies two issues:

1. The idle AUX voltage level is measured and compared to provided parameters. The voltages are expected to match values defined by resistor dividers set by connected DisplayPort sink and source devices.
2. The TE creates a short HPD pulse to have the DUT to generate an AUX request. The DUT is expected to read DPCD register address range 0x200 – 0x205. Test captures the sync sequence of the AUX transaction and verifies the unit interval timings.

The test is first done to AUX- line and then to AUX+ line.

### Parameters in use

- Test Timeout (default 5 000 ms)
- AUX+ line idle low voltage limit (default 2 400 mV)
- AUX+ line idle high voltage limit (default 3 600 mV)
- AUX– line idle low voltage limit (default 2 400 mV)
- AUX– line idle high voltage limit (default 3 600 mV)
- AUX+ line signal trigger low level (default 150 mV)
- AUX+ line signal trigger high level (default 200 mV)
- AUX– line signal trigger low level (default 200 mV)
- AUX– line signal trigger high level (default 5 mV)
- AUX signal capture timeout (default 4 ms)
- AUX signal capture attempts (default 20 times)

## Link Config Tests – DP Rx

Role:	Product:
DP Reference Sink (DP RX)	UCD-301, UCD-323
DP Alt Mode Reference Sink (DP RX)	UCD-340

Name	Value
Test timeout, in milliseconds	5000
Max lanes count supported by DUT	4
Max lane rate supported by DUT	5.4 Gbps
Long HPD pulse duration, in milliseconds	1000
Link training start timeout, in milliseconds	5000
Delay between test cycles, in milliseconds	3000
Reserved	0

### Link Training at All Supported Lane Counts and Link Rates

Test requests link training on all supported lane counts and link rates. Each link training must be successfully completed in order to pass the test.

#### Parameters in use

- Test Timeout (default 5 000 ms)
- Max lane count supported by DUT (default 4)
- Max lane rate supported by DUT as multiple of 0.27 Gbps. (valid settings 6, 10 and 20; default 20)
- Long HPD pulse duration (default 1 000 ms)
- Link training start timeout (default 5 000 ms)
- Delay between test cycles (default 3 000 ms)

## Pixel Level Video Tests – DP Rx, HDMI Rx

Role:	Product:
DP Reference Sink (DP RX)	UCD-301, UCD-323
HDMI Reference Sink (HDMI RX)	UCD-301, UCD-323
DP Alt Mode Reference Sink (DP RX)	UCD-340

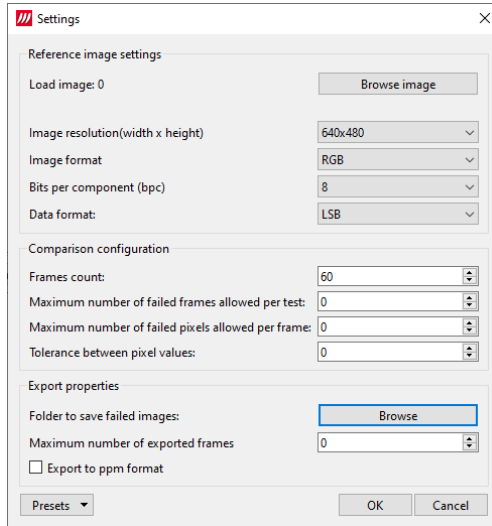

### Compare a defined number of captured frames to a single reference frame.

The test will capture the required number of consecutive frames into system RAM and then perform analysis between each frame and reference frame. Test is considered passed if the number of failed frames does not exceed the programmed value.

#### Parameters in use

<i>Load image:</i>	Load the reference image
<i>Image resolution:</i>	Video resolution expected
<i>Image format:</i>	Image format expected
<i>Bits per component:</i>	Bits per component expected
<i>Data format:</i>	Video data format expected
<i>Frames count:</i>	Number of frames buffered for testing
<i>Maximum number of failed frames allowed per test:</i>	Number of failed frames allowed totally
<i>Maximum number of failed frames allowed per test:</i>	Number of failed pixels allowed per buffered frame
<i>Tolerance between pixel values:</i>	The allowed difference between a color component of pixel in the captured frame to the reference bitmap.
<i>Folder to save failed images:</i>	PC folder where failed frames are stored.
<i>Maximum number of exported frames:</i>	Maximum number of failed frames stored to PC
<i>Export to ppm format</i>	
<i>Presets:</i>	Store and recall settings



## USB-C Electrical Test Set – DP Rx, DP Tx

Role:	Product:
DP Alt Mode Reference Source (DP TX)	UCD-340 with Unigraf Electrical Test Cable
DP Alt Mode Reference Sink (DP RX)	UCD-340 with Unigraf Electrical Test Cable

Electrical Tests verify the continuity of the interface signals and the voltage levels applied by the driving electronics.

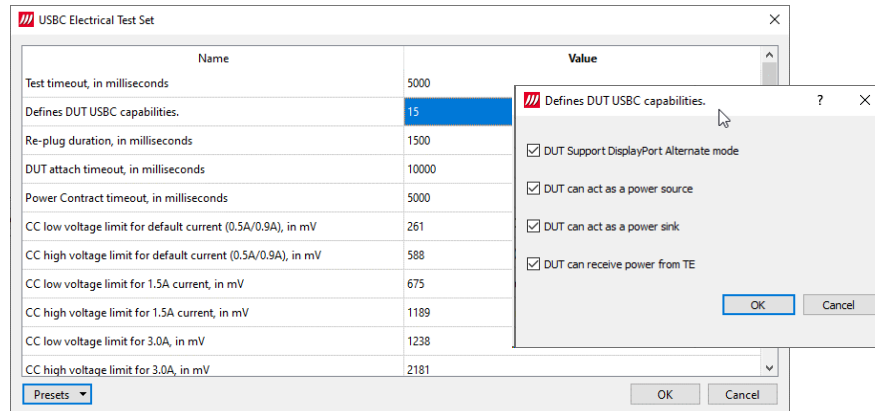

### Up Face Port CC and Vconn Test

This test verifies operation of CC lines for short-circuit and open-circuit failures, and that hardware directly related to CC lines is working properly. During the test, TE will operate as Type-C UFP device.

In the start of the test TE temporarily disconnects the CC lines to simulate a re-plug event.

After the re-plug event, Ra is connected to CC2, and Rd is connected to CC1. DUT is expected to have Rp, or a current source applied to both CC1 and CC2 lines. The impedance of DUT's Rp resistor, or current source must be adjusted so that the voltage drop on Rd resistor in TE is within one of the voltage ranges defined by the provided parameters. TE will measure the voltage drop on Rp.

Once DUT has started to provide Vconn on CC2, TE will measure the voltage present on CC2. After that TE will do a cable-flip and repeat the steps as above.

For a PASS result, measured values from CC1, CC2 and Vconn must be within ranges defined by the provided parameters.

**Note:** Configuration items for this test should be programmed with averaged values from several "golden sample" DUT's.

**Important:** In order to run this test with UCD-340, **Unigraf Electrical Test Cable** must be used, and Electrical Testing feature enabled with a corresponding license.

#### Parameters in use

- Test timeout (default 5 000 ms)
- R-plug duration (default 1 500 ms)
- DUT attach timeout (default 10 000 ms)
- CC low voltage limit for default current (0.5/0.9A) (default 261 mV)
- CC high voltage limit for default current (0.5/0.9A) (default 588 mV)
- CC low voltage limit for 1.5A current (default 675 mV)
- CC high voltage limit for 1.5A current (default 1 189 mV)
- CC low voltage limit for 3A current (default 1 238 mV)
- CC high voltage limit for 3A current (default 2 181 mV)
- Vconn low voltage limit (4 750 mV)
- Vconn high voltage limit (5 500 mV)

### AUX (SBU) Lines Test

This test verifies operation of SBU lines for short-circuit and open-circuit failures and that hardware directly related to SBU lines is working properly. During the test the TE will operate as Type-C UFP device. For this test, DUT must support DisplayPort Alternate Mode.

In the start of the test TE temporarily disconnects the CC lines to simulate a re-plug event and waits for DUT to enter DP Alternate mode.

Once DUT has entered the DP alternate mode, TE will measure voltage levels on SBU1 (AUX+) and SBU2 (AUX-) lines. Please notice that if TE is acting as DP Sink, it will de-assert HPD signal to keep AUX bus at IDLE state during the voltage measurements.

Once the voltages are measured, TE will do a cable-flip and repeat the steps as above.

For a PASS result, the measured voltages must be within the ranges defined by the provided parameters.

---

**Note:** Parameters for this test should be programmed with averaged values from several “golden sample” DUT’s.

---

**Important** In order to run this test with UCD-340, **Unigraf Electrical Test Cable** must be used, and Electrical Testing feature enabled with a corresponding license.

---

#### Parameters in use

- Test timeout (default 5 000 ms)
- DUT Capabilities flags (default 7)

Bits	Description
0	DUT Support for DisplayPort Alt Mode (1 Yes, 0 No)
1	DUT can act as power source (1 Yes, 0 No)
2	DUT can receive power from TE (1 Yes, 0 No)
3	DUT support for Power Delivery Contract (1 No, 0 Yes)
31:4	Reserved

- R-plug duration (default 1 500 ms)
- DUT attach timeout (default 10 000 ms)
- DP Alt Mode timeout (default 5 000 ms)
- DP Alt Mode AUX+ line idle low voltage (default 100 mV)
- DP Alt Mode AUX+ line idle high voltage (default 600 mV)
- DP Alt Mode AUX– line idle low voltage (default 2 500 mV)
- DP Alt Mode AUX– line idle high voltage (default 3 000 mV)

### DUT as Power Sink

This test verifies operation of Vbus and GND lines for short-circuit and open-circuit failures. The test is performed using mandatory PDO for power contract. During the test, the TE will operate as power source, and advertise only **vSafe5V** for power contract. In order to run this test, the DUT must support Power Sink role.

In the start of the test TE temporarily disconnects the CC lines to simulate a re-plug event and waits for Power Contract to be established.

After Power Contact has been established TE will wait for the delay stated in *Measurement delay* parameter and measures the current in Vbus and GND lines and the voltage of Vbus. The purpose of the delay is to allow the DUT time to stabilize its power consumption.

---

**Note:** The test assumes that the current flows through the four separate Vbus and GND lines evenly. Since current measurements are done sequentially, any variance in DUT power consumption during the measurement can cause this test to fail.

---

Total currents are calculated for Vbus, and for GND. The difference in the measured values of the four connections may not exceed the programmed deviation limits.

For PASS result, the measured Vbus voltage, Vbus current and GND line current must be within the ranges defined by provided parameters.

---

**Important:** In order to run this test with UCD-340, **Unigraf Electrical Test Cable** must be used and Electrical Testing feature enabled with a corresponding license.

---

#### Parameters in use

- Test timeout (default 5 000 ms)
- DUT Capabilities flags (default 7)

Bits	Description
0	DUT Support for DisplayPort Alt Mode (1 Yes, 0 No)
1	DUT can act as power source (1 Yes, 0 No)
2	DUT can receive power from TE (1 Yes, 0 No)
3	DUT support for Power Delivery Contract (1 No, 0 Yes)
31:4	Reserved

- R-plug duration (default 1 500 ms)
- DUT attach timeout (default 10 000 ms)
- Power Contract timeout (default 10 000 ms)
- Vbus voltage low limit (default 4 750 mV)
- Vbus voltage high limit (default 5 500 mV)
- Vbus current deviation (between wires) (default 100 mA)
- Return (GND) current deviation (between wires) (default 100 mA)
- Measurement delay (default 2 000 ms)
- Minimal current (default 20 mA)

## DUT as Power Source

This test verifies operation Vbus and GND lines for short-circuit and open-circuit failures. During the test, TE will operate as power sink and selects only **vSafe5V** PDO for power contract. In order to run this test, the DUT must support Power Source role.

In the start of the test TE temporarily disconnects the CC lines to simulate a re-plug event and waits for Power Contract to be established

After Power Contact has been established TE will wait for the delay stated in *Power measurement delay* parameter and measures the current in Vbus and GND lines and the voltage of Vbus. The purpose of the delay is to allow the DUT time to stabilize its power consumption.

---

**Note:** The test assumes that the current flows through the four separate Vbus and GND lines evenly. Since current measurements are done sequentially, any variance in DUT power consumption during the measurement can cause this test to fail.

---

Total currents are calculated for Vbus, and for GND. The difference in the measured values of the four connections may not exceed the programmed deviation limits.

For PASS result, the measured Vbus voltage, Vbus current and GND line current must be within the ranges defined by provided parameters.

---

**Important** In order to run this test with UCD-340, **Unigraf Electrical Test Cable** must be used and Electrical Testing feature enabled with a corresponding license.

---

### Parameters in use

- Test timeout (default 5 000 ms)
- DUT Capabilities flags (default 7)

Bits	Description
0	DUT Support for DisplayPort Alt Mode (1 Yes, 0 No)
1	DUT can act as power source (1 Yes, 0 No)
2	DUT can receive power from TE (1 Yes, 0 No)
3	DUT support for Power Delivery Contract (1 No, 0 Yes)
31:4	Reserved

- R-plug duration (default 1 500 ms)
- DUT attach timeout (default 10 000 ms)
- Power Contract timeout (default 10 000 ms)
- Vbus voltage low limit (default 4 750 mV)
- Vbus voltage high limit (default 5 500 mV)
- Vbus current deviation (between wires) (default 100 mA)
- Return (GND) current deviation (between wires) (default 100 mA)
- Measurement delay (default 2 000 ms)

## VRR Source DUT Tests – HDMI Rx

Role:	Product:
HDMI Reference Sink (HDMI RX)	UCD-301, UCD-323

### Parameters in use

- VRR Max – maximum VRR frame rate value;
- VRR Min – minimum VRR frame rate value;
- VRR value – static VRR frame rate value;
- VRR delta – value to change current VRR value during a test;
- VRR Time – value to change current VRR value during a test;

### Static VRR Test

Test verifies that DUT Source applies expected static VRR value.

After configuring the parameters operator starts the test. Test waits until DUT Source starts VRR mode. When VRR mode is detected, test verifies that received timing matches the VRR Value parameter and the data in received EMP packets match the timing.

### Quick Media Switching (QMS) Test

Verify that VRR is set correctly when frame rate is changing with a set time interval. For example, change VRR from 30 to 60 Hz with step 1 each 1 second.

After configuring the parameters operator starts the test. Test waits until DUT Source starts VRR mode. When VRR mode is detected, test verifies that VRR is changed after each time interval set by VRR Time parameter, and the applied VRR change is as set in the parameter. Test also verifies that data in received EMP packets match with applied VRR.

### Dynamic Test

Verify that VRR is set correctly when frame rate is changing with each frame. For example, change VRR from 60 to 120 Hz with step 1 each frame.

After configuring the parameters operator starts the test. Test waits until DUT Source starts VRR mode. When VRR mode is detected, test verifies that VRR is changed between each frame. Test also verifies that data in received EMP packets match with applied VRR.

## VRR Sink DUT Tests – HDMI Tx

Role:	Product:
HDMI Reference Source (HDMI TX)	UCD-323

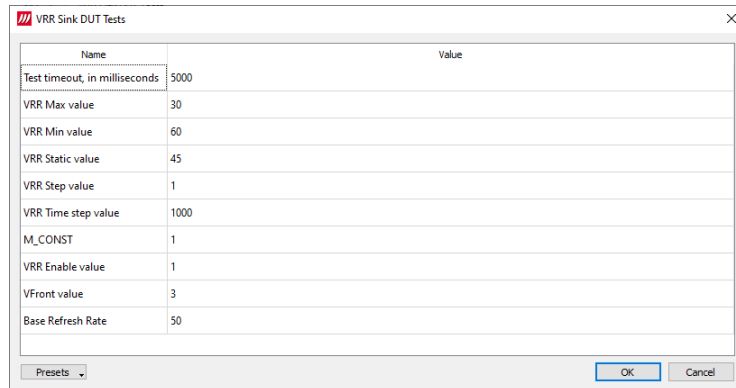

### Parameters in use

- VRR Max – maximum VRR frame rate value;
- VRR Min – minimum VRR frame rate value;
- VRR value – static VRR frame rate value;
- VRR delta – value to change current VRR value during a test;
- VRR Time – value to change current VRR value during a test;

### Static VRR Test

Test verifies that DUT Sink correctly applies a static VRR value.

After configuring the parameters operator starts the test. Operator verifies that DUT Sink has applied VRR correctly and provides the information in the dialog of the test.

### Quick Media Switching (QMS) Test

Verify that VRR is set correctly when frame rate is changing with a set time interval. For example, change VRR from 30 to 60 Hz with step 1 each 1 second.

After configuring the parameters operator starts the test. Operator verifies that DUT Sink has applied VRR correctly and frame rate is changing as expected. Operator provides the information in the dialog of the test.

### Dynamic Test

Verify that VRR is set correctly when frame rate is changing with each frame. For example, change VRR from 60 to 120 Hz with step 1 each frame.

After configuring the parameters operator starts the test. Operator verifies that DUT Sink has applied VRR correctly and frame rate is changing as expected. Operator provides the information in the dialog of the test.

## APPENDIX F: VPATTERN LANGUAGE

### General

The Vpattern definition language (in the following simply “VTP”) is a straightforward yet flexible way of describing test patterns for UCD Generators. This description is providing an introduction and examples of the most usable instructions and parameters.

The VTP language uses text command syntax. Each row represents one drawing instruction. The coordinate system can be either absolute or scaled. In the absolute mode the actual pixel position is referred while in the scaled mode the coordinates refer to the “Drawing resolution” used while drawing. For both absolute and scaling coordinates the origin is the upper left hand corner of the screen.

### Terminology

The following terms are used in this document:

*Coordinate system*: two numerical ranges of integer, positive numbers. E.g. {0,799},{0,599} or {0,10000},{0,10000}.

*Coordinates*: a tuple of integer, positive numbers used to address a position on an image, e.g. (100,250). The first number is the horizontal position, the second one the vertical position. The actual position is always related to the coordinate system currently in use

*Drawing resolution*: the width and height of the space that can be used for drawing, expressed in pixels. E.g., 2560 by 1600.

*Drawing area*: a 2-dimensional area spanning all of the drawing resolution, expressed in the current coordinate system notation. E.g., if the drawing resolution is 800 x 600 pixels, the drawing area includes all points (x,y) where x = 0 to 799 and y = 0 to 599 in ABSOLUTE mode or x = 0 to 10000 and y = 0 to 10000 in SCALED mode.

### Notation

The following notation is used in this document:

- A token is enclosed by characters ‘<’ and ‘>’. For instance, <variable> represents a generic variable.
- Different legal choices for a command parameter are separated by character ‘|’. For instance, <variable> | <number> means that either variable or number can be used as parameters.
- Items that can be repeated 0, 1 or more times are preceded by ‘{’ and followed by ‘}\*’. For instance {<number>}\* means zero, one or more occurrences of a number.

### Syntax rules

The following general syntax rules apply to VTP language files:

- The VTP is a text-based, interpreted language
- Commands, variables, and constant names are not case-sensitive.
- All text at the right of a semicolon (;) is treated as comment.
- All strings are delimited by quotation marks (“a string”). Quote and backslash characters must be prefixed by the backslash symbols (“ a quote \” and a backslash \\”).
- Filenames cannot contain pathnames.

## Commands

### Scaling commands

All drawing commands using coordinates can refer either to absolute or scaled coordinates. The absolute coordinate system starts at 0 and its measurement unit is the pixel (vertically the line). It extends up to the maximum drawing resolution in use minus one, expressed in pixels too.

Conversely, the scaled coordinate system ranges from 0 to 10000, independently from the drawing resolution. Its measurement unit is thus a flexible, virtual pixel.

Absolute coordinates provide the fastest drawing speed, but they are resolution specific. Scaled coordinates are resolution independent while introducing a slight speed penalization.

For both systems, the origin (0,0) refers to the upper left hand corner of the screen.

#### ABSOLUTE

```
Syntax: ABSOLUTE
```

This command is normally used in the beginning of the VTP file. All drawing commands issued after ABSOLUTE will have absolute coordinate values, i.e., their coordinates will be interpreted as pixels and lines.

The allowed coordinate values are from 0 to the maximum drawing resolution minus one. For instance, for a drawing resolution of 2560 x 1600 pixels, the allowed coordinate range (x,y) for x is 0 to 2559 and for y 0 to 1599.

Constants MAXX and MAXY can be used in place of the numeric values to achieve basic scaling capabilities.

#### SCALED

```
Syntax: SCALED
```

All drawing commands issued after the SCALED command will have their coordinates interpreted as within a range from 0 to 10000 (10001 possible coordinate values), regardless of the current drawing resolution. Positioning can be calculated as percentages. If you wanted to address a point at 50% of the drawing resolution, then you would use the number 5000. If you wanted 75% you would simply use the 7500.

### Graphics Drawing Commands

All of the following graphics drawing commands use the currently selected foreground color for shape perimeter and filling.

#### LINE

```
Syntax: LINE x1 y1 x2 y2
```

Draws a line from point (x1,y1) to point (x2,y2).

Example:

You can draw a white diagonal cross using either ABSOLUTE and SCALED coordinate mode and get the same result.

*ABSOLUTE ; Set scaling mode to absolute*

*COLORDEPTH 8 ; 8 bits per color*

*COLORRGB 255 255 255 ; white*

*LINE 0 0 MAXX MAXY ; Draw a line from upper left to lower right corner*

*LINE 0 MAXY MAXX 0 ; Draw a line from lower left to upper right corner*

*Or if you want a fixed size for 640 x 480 resolution*

*LINE 0 0 639 479*

*LINE 0 479 639 0*



The pattern will look like this:

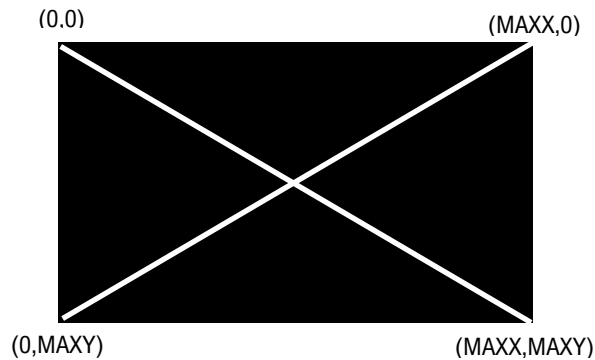

Using SCALED instead of ABSOLUTE.

```
SCALED
COLORDEPTH 8
COLORRGB 255 255 255
LINE 0 0 10000 10000
LINE 0 10000 10000 0
```

### BOX

```
Syntax: BOX x1 y1 x2 y2
```

Draws a filled rectangle with upper left corner (x1,y1) and lower right corner (x2,y2).

Example:

This code will create a full white screen with all resolutions.

```
SCALED
COLORDEPTH 8
COLORRGB 255 255 255
BOX 0 0 10000 10000
```

### DOT

```
Syntax: DOT x y
```

Draws a single dot at location (x,y).

### FILL

```
Syntax FILL x y
```

Initiates a flood fill (or seed fill) with foreground color starting from position (x,y).

### CIRCLE

```
Syntax: CIRCLE x y r
```

Draws a circle with center point at (x,y) and radius r. Please, note that when using SCALED coordinates radius r is expressed as a vertical measure.

Example:

```
SCALED
COLORDEPTH 8
COLORRGB 255 255 255
CIRCLE 5000 5000 50
```

The pattern will look like this:

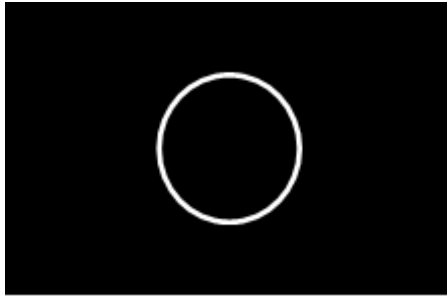

### FCIRCLE

Syntax: FCIRCLE x y r

Draws a circle with center point at (x,y) and radius r. Filled with foreground color. Please, note that when using SCALED coordinates radius r is expressed as a vertical measure.

The pattern will look like this:

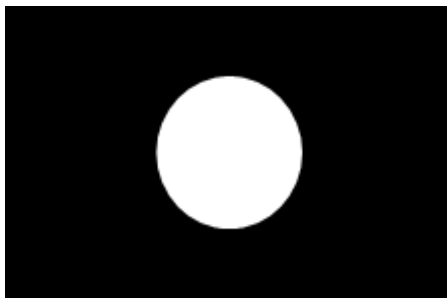

### ELLIPSE

Syntax: ELLIPSE x y hr vr

Draws an ellipse with center point at (x,y), horizontal radius hr and vertical radius vr.

You can use ELLIPSE instead of CIRCLE for example when the displayed pixel is not square for compensating the stretching.

Example:

```
SCALED
COLORDEPTH 8
COLORRGB 255 255 255
ELLIPSE 5000 5000 3000 4000
```

The pattern will look like this:

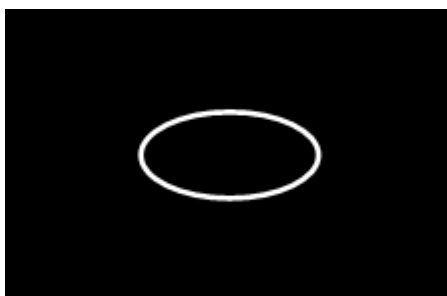

## Text Drawing Commands

All of the following commands use the currently selected foreground color for the “foreground” pixels of the font and the currently selected background color for “background” pixels.

### TEXTPOS

```
Syntax: TEXTPOS x y
```

Sets the text drawing position to point (x,y).

### TEXT

```
Syntax: TEXT <string> | <var> | <const> { <string> | <var> | <const> }*
```

The command executes a CR and LF (carriage return and line feed) and then draws a text string <string>, a variable <var>, a constant <const> or a combination of them starting from the current text position.

<string> parameter is a quoted sequence of characters. If the string contains a quote character (") or a backslash character (\) then it must be preceded with a back slash character (\).

<var> is a parameter variable (A – Z, MAXX, MAXY) defined by SET command.

<const> one of the Timing Variables. Timing variables are defined by currently loaded timing parameters. Please refer to Chapter 3.

---

**Note:** Please note that when using the timing parameters in a pattern the display will be redrawn every time the timing is changed. Normally the VTG does not have to redraw the picture when only e.g., the horizontal sync is changed, but if the HS variable is used in the pattern it needs to be updated to display the new value.

---

Example:

```
ABSOLUTE
COLORDEPTH 8
COLORRGB 255 255 255
TEXTPOS 100 100 ; Text starting point 100 pixels from left edge and 100 display
lines down from top
TEXT "HRES=" HR " PIXELS ; This will draw the text HRES then the
variable HR value and PIXELS
TEXT "Quote character \" and backslash \\"
```

## Program Flow Commands

### REPEAT

Syntax: REPEAT <variable> a b s

All commands after between REPEAT and END command are repeated the number of times defined by <variable>. <variable> is set to value a before starting the first iteration loop. At the end of each iteration, variable is incremented by s (variable = variable + s). The REPEAT is terminated when variable reaches or exceeds value b, and the execution continues from the command following the END command. For example:

```

SCALED
COLORDEPTH 8
COLORRGB 255 255 255
REPEAT W 0 10000 200
LINE W 0 W 10000
END

```

A maximum of 2 REPEAT loops can be nested (placed inside each other).

### END

Syntax: END

This command follows a REPEAT command and defines a group of instructions to be repeated.

## Color Commands

The user can assign the used colors in two basic ways: either by giving the actual Red, Green and Blue (or R, G and B) color component values or using pre-defined color palettes. The first method is referred as True Color Mode and the latter as Palette Mode.

In True Color Mode the numerical values given for R, G and B will be the actual output signal intensity values for the pixel in question. The numerical color value in Palette Mode will act as an address (or index) to a pre-defined color in a 256 color table. The output signal intensity will be the R, G and B value entry in the cell where the address points to.

Palette mode can only be used with True Color Mode is .

### COLORDEPTH

Syntax: COLORDEPTH n

The command is used in True Color Mode (COLORMODE 2), to define the number of bits used for each color component (R, G and B) of the data to be displayed. Possible values for the parameter n are 6, 8, 10 and 12. If COLORDEPTH command is not used, 10 bits per color is used.

Example: To display a bitmap that uses 8 bits for r, g and b (24-bit colors) you have to use COLORDEPTH 8.

Command	Nr of color bits	Range of values for R, G and B
COLORDEPTH 6	18	0 to 63
COLORDEPTH 8	24	0 to 255
COLORDEPTH 10	30	0 to 1023
COLORDEPTH 12	36	0 to 4095

COLORDEPTH can be used only once in a VTP file, and it has to be placed before all drawing instructions it is supposed to affect.

## COLORRGB

```
Syntax: COLORRGB r g b
```

The command defines the foreground color used for the following drawing commands. The command is used in True Color Mode only.

The range of values for r, g and b depends on the bits per color used. If not changed with COLORDEPTH command, 10 bits per color is used. Please refer to COLORDEPTH command for range of values.

## Various Commands

### SET

```
Syntax: SET <variable> n
```

Assigns value n to programming variable called variable. n must be a positive number or zero.

## Variables

### Timing Variables

Timing Variable	Value name
HF	Drawing resolution horizontal size minus one
HP	Drawing resolution vertical size minus one
HR	Current timing horizontal frequency (MHz?)
HA	Current timing horizontal period (pixels)
HS	Current timing horizontal resolution (pixels)
HBP	Current timing horizontal active time (pixels)
HFP	Current timing horizontal sync length (pixels)
VF	Current timing horizontal back porch length (pixels)
VP	Current timing horizontal front porch length (pixels)
VR	Current timing vertical frequency (MHz?)
VA	Current timing vertical period (lines)
VS	Current timing vertical resolution (lines)
VBP	Current timing vertical active time (lines)
VFP	Current timing vertical sync length (lines)
PF	Current timing vertical back porch length (lines)
HLB	Current timing vertical front porch length (lines)
HRB	Pixel frequency (Mpps?)
VTB	Drawing resolution horizontal size minus one
VBB	Drawing resolution vertical size minus one

### Expressions

Any command numeric parameter can be replaced by an expression, according to the syntax below:

`<term> ::= <variable> | <constant> | <number>`

`<expression> ::= <term> { '+' | '-' | '*' | '/' | '%' } <term>`

`<parameter> ::= <term> | <expression>`

Some example of legal parameter values:

```

B
MAXX
342
B + MAXX
B / 2
B * C

```

Expressions have always positive integers or zero value. When an expression evaluates to a negative value, it is set automatically to zero. Number values are also always positive integers or zero.

## Assignments

A variable can be assigned a numerical value by using the SET command.

The second parameter of the SET command can be replaced by an expression thus allowing commands like those here below:

```
SET C B+MAXX
```

```
SET K K+1
```

```
SET K A+B
```

## Default state at VTP execution startup

Coordinate system: ABSOLUTE

Foreground color: 1023 1023 1023

Background color: 0 0 0

Output image is cleared (all black)

All variables are initialized to zero

```
COLORDEPTH 10
```

## APPENDIX H: PLAYLISTS AND SCENARIOS

UCD Console's Playback tab enables the user to execute playback macros called Playlists. Playlists define the video and audio content and the related metadata steamed in predefined sequences.

### Playlist

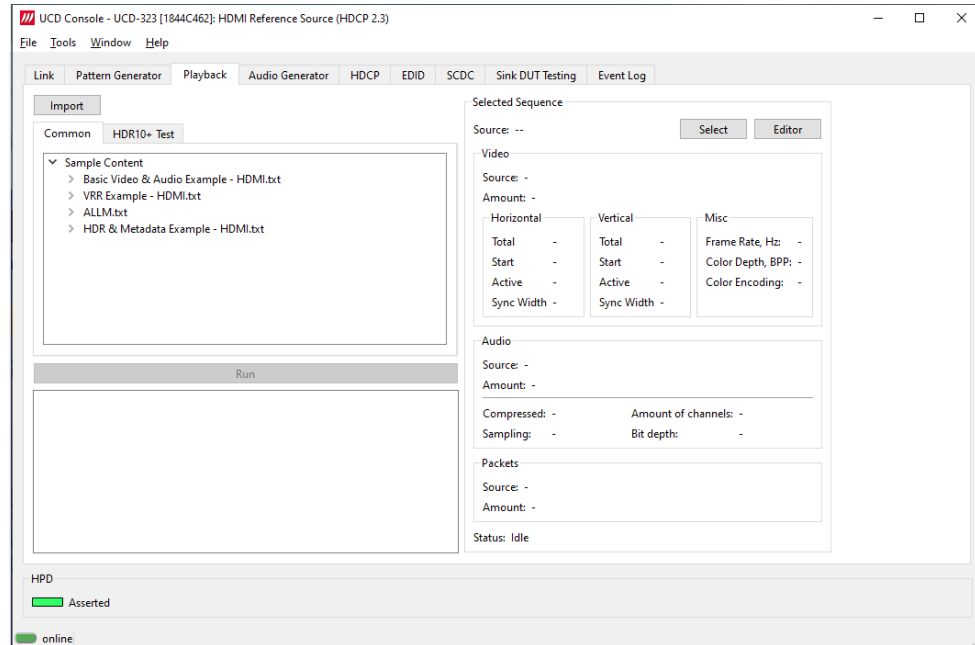

*Playlist* defines the UCD device and the output where the content is played. It lists the played Scenarios and their duration.

### Scenario

*Scenario* is an operating structure that allows user to determine a specific sequence of video frames, metadata packets and audio that are going to be played in the defined order.

Playlists and Scenarios are stored as human readable text files. The files can be edited using any text-editor software.

### Frame Memory

When played, all content is first loaded to the frame memory buffer of the UCD device. This enables smooth transition between content items during execution of the Scenario.

The size of frame buffer memory sets a limit for content that can be played. In their default configuration UCD devices feature a 2 GBytes frame buffer memory. This frame buffer enables loading up to 40 pcs 4K video frames or 10 pcs 8K video frames simultaneously.

Please also refer to UCD-323 HDDP 4G (P/N 066520), a model with 4 Gigabytes frame buffer memory, please contact Unigraf.

### Sample Content

UCD Console's Playback tab features a set of sample content. These examples can be used as a basis for creating custom test sequences. The sample content is stored as files by default in `C:\Program Files\Unigraf\Unigraf UCD Tools\data\playback\content`. It is advisable to create copy of the installed original files and edit the copies.

Please find a description of the sample content later in this Appendix.



## Playlists

Playlist defines the UCD device and the output where the content is played. It lists the played video and audio sequences called Scenarios and their duration.

Playlists are stored as human readable text files. The files can be edited using any text-editor software. It is advisable to create copy of the installed original files and edit the copies.

---

**Note:** Please note that Playlists and Scenarios are interface technology dependent.

---

### Device section

Section describes what device and what output connector to use.

Key	Description	Possible values
[Device]	Required. Start of the Device section.	
serialnumber	Required. Specifies serial number of the UCD device. The '*' wildcard can be used if only one UCD source device is connected to the PC.	'*' '1722C333'
connectortype	Required. Specifies output connector to be used. Playlist cannot contain scenarios for different connector types.	'HDMI Out' 'DisplayPort Out' 'USBC Out'
reset	Optional. '1' = UCD device is restarted after playlist completion Device restart takes approximately up to 5 seconds. Only for use with UCD-323.	'0' or '1' Default '0'

### Scenario section

Section describes selected scenario and its playback parameters. Playlist runs scenarios in the order they are listed in the Playlist file.

Key	Description	Possible values
[Scenario]	Required. Start of a Scenario section. Playlist can have multiple Scenario sections.	
caption	Optional. Title of the Scenario. Any character string accepted.	'Scenario 1' 'Playlist completed'
path	Required. Specifies path to scenario file.	Any path
period	Required. Duration of Scenario in msec. The duration is ignored if close-after-upload is set to '1'.	'60000' '5000'
close-after-upload	Optional. When set to '1', command line version of the Playback tool will exit after loading scenario content and starting playback.	'0' or '1' Default '0'
execute-after-upload	Optional. Executes provided command in cmd.exe or bash and waits for its completion. Calculation of 'period' starts after the command is executed.	'script.bat && dir' 'rmdir '/home/user/test'

## Scenarios

Scenario is an operating structure that allows user determine a specific sequence of video frames, events and audio that are going to be played in a certain order. In addition, scenario determines environment for sequence to play.

Scenarios are stored as human readable text files. The files can be edited using any text-editor software. It is advisable to create copy of the installed original files and edit the copies.

---

**Note:** Please note that Playlists and Scenarios are interface technology dependent.

---

## Parameters

Scenario parameters are defined as a list of items. Please find below a description of Scenario items.

Scenario item and example content	Description
video=Video/FHD/8RGB444/Video_0000.bin	Path and file name format of video frame files
audio=	Audio not selected
packets=Infoframes/Infoframes_0000.bin	Path and file name format of metadata packet files
porder=0-79:1:18,0:256;	Content Playing Order. Please see <i>Content Playing Order</i> below.
align12=1	'1' 12bit binary pixel data is aligned to LSB '0' 12bit binary pixel data is aligned to MSB.
audioswap=0	'1' for Little Endian audio samples
audiocompressed=0	1 compressed audio; 0 uncompressed audio
audiosampling=0	Audio sampling rate. E.g. 44100
audiochannels=0	Nr. of audio channels
audiobits=0	Audio bits per sample (usually 16 or 24)
scrambler=0	1 scrambling enabled; 0 scrambling disabled
colorspace=RGB444	Video color space
bitspercolor=8	Video color depth (bpc)
timing.hactive=1920	Timing: Horizontal active
timing.vactive=1080	Timing: Vertical active
timing.htotal=2200	Timing: Horizontal total
timing.vtotal=1125	Timing: Vertical total
timing.hstart=192	Timing: Horizontal start
timing.vstart=41	Timing: Vertical start
timing.hsync=44	Timing: Horizontal sync width
timing.vsync=5	Timing: Vertical sync width
timing.frate=59940	Timing: Frame rate [fps] × 1000
hdcp=v23	HDCP: (HDCP version 2.3 used)
loadingRGB=52,127,150	The R, G and B color components of solid color pattern shown when content is being uploaded to the device before playback

## Content Playing Order

Playing order is described in a textual format as a sequence of steps. Steps are separated with ‘;’ symbol.

Each step describes:

- Index of played video frame or a range of video frames,
- How many times the frame(s) are played,
- Index of the packet or the set of packets that will be sent during the video frame(s),
- Color format used for the step.

### Format structure

Each scenario step is described in following textual format:

```
pV:R:E:FvXX;
```

### Parameters

Please see table below for description of used parameters.

Char	Description	Possible values	Examples
:	Required. Separator between general step parameters.	‘.’	<i>See any below</i>
;	Required. Indication of step description end.	‘;’	<i>See any below</i>
p	Optional. Indicates assertion of a HPD pulse on HDMI RX connector of UCD device during current step. Preceding video frame index. Only for HDMI playback.	‘p’	‘p1:60:1:256;’ ‘p0-59:60:1:256;’
V	Required. Index of a video frame. Index is zero based. Images are loaded from the indicated file path. Parameter can state either a single image or a range of images. The order in which images are called in scenario steps is optional. All specified parameters are applied to all frames in the scenario step.	‘1’ ‘0-59’	‘1:60:16:256;’ ‘0-59:60:16:256;’
R	Required. Repetitions of current step. E.g., stating ‘1’ with 60 FPS frame rate means that current step will be played only for 1/60 of a second.	‘30’ ‘1’	‘1:30:16:256;’ ‘1:1:16:256;’
E	Optional. Index of metadata packet. Index is zero based. Packets are loaded from the indicated file path. Parameter can indicate either a single packet or a comma separated list of packets. Order of packets is optional.	‘0’ ‘4,1,29’ <i>none</i>	‘1:30:0:256;’ ‘1:30:4,1,29:256;’ ‘1:30::256;’
F	Required. Color Format and color depth. Pls see chapter Color Format below.	‘256’ ‘513’	‘1:30:0:256;’ ‘1:30:0:513;’
vXX	Optional. Control of frame rate when VRR is enabled. In order to enable VRR, corresponding HDMI VSIF event must be included into this step. Parameter is always in format of ‘vXX’, where ‘XX’ states frame rate. Parameter is provided with color format value, separated with ‘v’.	‘v60’ ‘v30’	‘1:30:0:256v60;’ ‘1:30:0:256v30;’

## Color Format

Color format is a two-byte value presented in decimal. The lower byte provides an index to used color space and the higher byte an index to the color depth. Please find the indexes in the table below.

Index	Color Depth (bits/color)	Color Space
0	6	RGB
1	8	YCbCr 4:4:4
2	10	YCbCr 4:2:2
3	12	YCbCr 4:2:0
4	16	–

The encoded parameter value is calculated using the following formula:

$$[Color\ Depth] \times 256 + [Color\ Space],$$

where *[Color Depth]* and *[Color Space]* are indexes obtained from the table above.

For example, parameter for YCbCr 4:4:4, 10 bits is  $(2 \times 256 + 1) = 513$ .

Pre-calculated values for available color formats:

	6 BPC	8 BPC	10 BPC	12 BPC	16 BPC
RGB	0	256	512	768	1024
YCbCr 4:4:4	N/A	257	513	769	1025
YCbCr 4:2:2	N/A	258	514	770	1026
YCbCr 4:2:0	N/A	259	515	771	1027

## Example

Please find below description of Playlist SDR-HDR-HLG – HDMI.

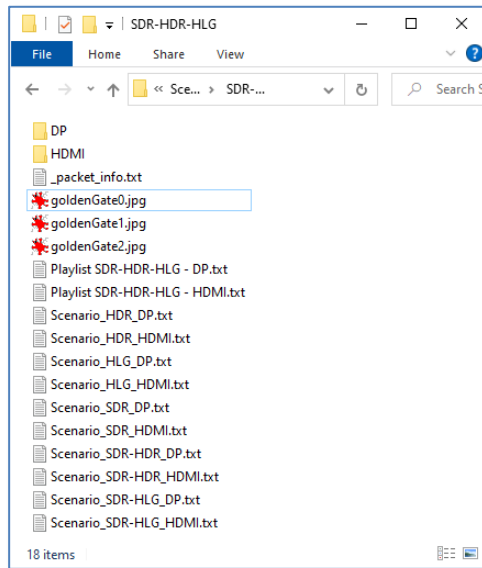

### Playlist file (Playlist SDR-HDR-HLG - HDMI.txt)

Playlist item and example content	Description
[Device]	Start of device section
serialnumber=*	Only one UCD device present.
connectortype=HDMI Out	HDMI output
[Scenario]	Start of Scenario 1
caption = SDR	Scenario title "SDR"
period = 10000	Duration 10 sec
path = Scenario_SDR_HDMI.txt	Scenario file: Scenario_SDR_HDMI.txt in current folder
[Scenario]	Start of Scenario 2
caption = HDR	Scenario title "HDR"
period = 10000	Duration 10 sec
path = Scenario_HDR_HDMI.txt	Scenario file: Scenario_HDR_HDMI.txt in current folder
[Scenario]	Start of Scenario 3
caption = HLG	Scenario title "HLG"
period = 10000	Duration 10 sec
path = Scenario_HLG_HDMI.txt	Scenario file: Scenario_HLG_HDMI.txt in current folder
[Scenario]	Start of Scenario 4
caption = SDR – HDR	Scenario title "SDR – HDR"
period = 10000	Duration 10 sec
path = Scenario_SDR-HDR_HDMI.txt	Scenario file: Scenario_SDR-HDR_HDMI.txt in current folder
[Scenario]	Start of Scenario 5
caption = SDR – HLG	Scenario title "SDR – HLG"
period = 10000	Duration 10 sec
path = Scenario_HDR_HDMI.txt	Scenario file: Scenario_SDR-HLG_HDMI.txt in current folder

## Scenario File (Scenario\_SDR-HDR-HDMI.txt)

Scenario item and example content	Description
video=goldenGate0.jpg	Video files in current folder, file name format goldenGate0.jpg (0...)
audio=<Audio not selected>	Audio not selected
packets=HDMI\Infoframes_0000.bin	Packet files in folder HDMI\, file name format Infoframes_0000.bin (0...)
porder=0:180:2:256;1:180:2,0:256;	180 frames of image index 0, Packet index 2, RGB 8 bpc 180 frames of image index 1, Packets index 2 and 0, RGB 8 bpc
align12=1	Pixel data is aligned to LSB
audioswap=0	-
audiocompressed=0	-
audiosampling=0	-
audiochannels=0	-
audiobits=0	-
scrambler=0	scrambling disabled
colospace=RGB444	Video color space: RGB 4:4:4
bitspercolor=8	Video color depth: 8 (bpc)
timing.hactive=1920	Timing: Horizontal active
timing.vactive=1080	Timing: Vertical active
timing.htotal=2200	Timing: Horizontal total
timing.vtotal=1125	Timing: Vertical total
timing.hstart=192	Timing: Horizontal start
timing.vstart=41	Timing: Vertical start
timing.hsync=44	Timing: Horizontal sync width
timing.vsync=5	Timing: Vertical sync width
timing.frate=60000	Timing: Frame rate 60 fps
hdcp=none	HDCP not enabled
loadingRGB=52,127,150	Solid color pattern shown when content is being uploaded to the device before playback is R=52, G=127, B=150. (Sample:  )

## Sample Content in Playback Tab

UCD Console's Playback tab features a set of examples for the user to create custom test content. This content is stored by default in *C:\Program Files\Unigraf\Unigraf UCD Tools\data\playback\content*. It is advisable to create copy of the installed files and edit the copies.

**Note:** Please note that Playlists and Scenarios are interface technology dependent. The provided examples are also somewhat different for HDMI and DisplayPort.

In the table below, please find a list of examples provided.

### HDMI

Playlist Name	Description
Basic Video & Audio Example	Example playlist for demonstrating the use of video and audio files.
HDR & Metadata Example	Example playlist that demonstrates the use of video files and metadata packets in testing a DUT monitor
VRR Example	Playlist for demonstrating Variable Refresh Rate (VRR) capability of a DUT monitor. Utilizes extensively frame sequencing capability in scenario, and the use of metadata packets.
QMS-VRR Example	
ALLM	Playlist for demonstrating Auto Low-latency Mode (ALLM) capability of a DUT monitor.

### DP

Playlist Name	Description
Basic Video & Audio Example	Example playlist for demonstrating the use of video and audio files.
HDR & Metadata Example	Example playlist that demonstrates the use of video files and metadata packets in testing a DUT monitor
Frame Rate Example	Playlist for demonstrating use of multiple frame rates with FHD and UHD resolution.

## Playlist: Basic Video & Audio Example

The playlist sequences video files and audio according to the description below.

### Video

Frames used for Scenario 1 and Scenario 2 (Image1.jpg, Image 2.jpg)



Frame used for Scenario 3 and Scenario 4 (Philips.svg)

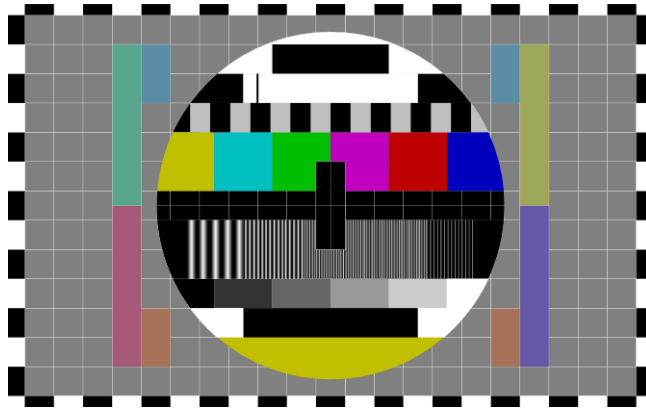

### Description of Scenarios

	Name	Duration	Repeated sequence
1	Flip-flop with Audio	60 s	CTA 1920×1080 60 Hz (VIC 16), RGB 8 BPC, 60 frames Image1.jpg, 60 frames Image2.jpg, Audio: Rhythm.wav
2	Flip-flop Silent	60 s	CTA 1920×1080 60 Hz (VIC 16), RGB 8 BPC, 60 frames Image1.jpg, 60 frames Image2.jpg, No Audio.
3	Philips 1920x1080p + 1kHz	60 s	CTA 1920×1080 60 Hz (VIC 16), RGB 8 BPC, 60 Frames Philips.svg, Audio: 1 kHz sine wave (1kHz.wav)
4	Philips 3840x2160p + 1kHz	60 s	CTA 3840 x 2160 @ 60Hz (VIC 97), RGB 8 BPC, 60 Frames Philips.svg, Audio: 1 kHz sine wave (1kHz.wav)



## Playlist: HDR & Metadata Example

Example demonstrates the use of metadata packets.

### Video:

The Scenarios use four versions of the same image: GoldenGate0.jpg, GoldenGate1.jpg, GoldenGate2.jpg and GoldenGate3.jpg.

All four images use the same dynamic range in pixel data but contain a text label indicating pixel dynamic range applied in the metadata. If DUT behaves correctly, applying different metadata changes the appearance of the image on DUT screen.



### Scenarios for HDMI Output

Video mode in all steps: CTA 1920×1080 60 Hz (VIC 16), RGB 8 BPC, No audio.

Name	Duration	Repeated sequence
SDR	10 sec	180 frames GoldenGate0.jpg, Packet: Infoframes_0002;
HDR	10 sec	180 frames GoldenGate1.jpg, Packets: Infoframes_0002, Infoframes_0000
HLG	10 sec	180 frames GoldenGate2.jpg, Packets: Infoframes_0001, Infoframes_0002
HDR10+	10 sec	180 frames GoldenGate3.jpg, Packets: Infoframes_0002, Infoframes_0003, Infoframes_0000
SDR – HDR	10 sec	180 frames GoldenGate0.jpg, Packets: Infoframes_0002; 180 frames GoldenGate1.jpg, Packets: Infoframes_0002, Infoframes_0000
SDR – HLG	10 sec	180 frames GoldenGate0.jpg, Packet: – ; 180 frames GoldenGate2.jpg, Packets: Infoframes_0001, Infoframes_0002
SDR – HDR10+	10 sec	180 frames GoldenGate0.jpg, Packet: Infoframes_0002; 180 frames GoldenGate3.jpg, Packets: Infoframes_0002, Infoframes_0003, Infoframes_0000

## Playlist: VRR Example (HDMI)

Playlist demonstrates controlling VRR (Variable Refresh Rate) in Scenarios when using HDMI output.

### Video

The image used for the test contains a combination of color bars, gray scales, and rotating items. The test uses a sequence of images creating a full rotation in 60 frames.



### Scenarios with Video Mode 1920.1080 120 Hz

The first 6 Scenarios are using 1920×1080 119.88/120 Hz video timing (VIC 63). No audio.

	Name	Duration	Repeated sequence
1	FHD No VRR 119	60 s	VRR disabled. RGB 8 BPC. Packet: infoframe_03
2	FHD VRR 119..40	60 s	VRR enabled. Packets: infoframe_00, infoframe_03 60 frames each with changing frame rate (Hz): 119, 112, 105, 97, 86, 73, 59, 45, 42, 41, 40, 43, 51, 67, 82, 95, 109, 113, 114, 115, 116, 117, 118.
3	FHD VRR 119..40 steps	60 s	VRR enabled. RGB 8 BPC. Packets: infoframe_00, infoframe_03 60 frames with changing frame rate: 119 – 80 (1 Hz step), 78 – 40 (2 Hz step), 60 frames with 40 Hz frame rate, 60 frames with changing frame rate, 40 – 79 (2 Hz step), 79 – 119 (1 Hz step). 60 frames with 119 Hz.
4	FHD VRR 40..119 switch	60 s	VRR enabled. RGB 8 BPC. Packets: infoframe_00, infoframe_03 300 frames with 40 Hz frame rate, 300 frames with 119 Hz frame rate
5	FHD VRR 60	60 s	VRR enabled. RGB 8 BPC. Packets: infoframe_00, infoframe_03 60 frames with 60 Hz frame rate.
6	FHD VRR 60..119 switch	60 s	VRR enabled. RGB 8 BPC. Packets: infoframe_00, infoframe_03 300 frames with 60 Hz frame rate, 300 frames with 119 Hz frame rate.

## Scenarios with Video Mode 1920.1080 60 Hz

Scenarios 7 to 11 are using 1920×1080 59.94/60 Hz video timing (VIC 16). No audio.

	Name	Duration	Repeated sequence
7	FHD No VRR 59	60 s	VRR disabled. RGB 8 BPC. Packet: infoframe_01
8	FHD VRR 40	60 s	VRR enabled. RGB 8 BPC. Packets: infoframe_00, infoframe_01 60 frames with 40 Hz frame rate.
9	FHD VRR 40..59 switch	60 s	VRR enabled. RGB 8 BPC. Packets: infoframe_00, infoframe_01 300 frames with 40 Hz frame rate, 300 frames with 59 Hz frame rate.
10	FHD VRR 59..40	60 s	VRR enabled. RGB 8 BPC. Packets: infoframe_00, infoframe_01 60 frames each with changing frame rate: 59, 52, 50, 48, 46, 45, 44, 43, 42, 41, 40, 41, 43, 45, 47, 49, 51, 53, 54, 55, 56, 57, 58 (Hz).
11	FHD VRR 59..40 steps	60 s	VRR enabled. RGB 8 BPC. Packets: infoframe_00, infoframe_01 29 frames with changing frame rate: 59 – 41 10 frames with 40 Hz frame rate, 29 frames with changing frame rate 41 – 59 40 frames with 60 Hz frame rate.

## Scenarios with Video Mode 3840.2160 120 Hz

Scenarios 12 to 18 are using 3840×2160 119.88/120 Hz video timing (VIC 120). No audio.

	Name	Duration	Repeated sequence
12	UHD No VRR 119	60 s	VRR disabled. RGB 8 BPC. Packet: infoframe_04
13	UHD VRR 119..40	60 s	VRR enabled. RGB 8 BPC. Packets: infoframe_00, infoframe_04 60 frames each with changing frame rate: 119, 112, 105, 97, 86, 73, 59, 45, 42, 41, 40, 43, 51, 67, 82, 95, 109, 113, 114, 115, 116, 117, 118 (Hz).
14	UHD VRR 119..40 steps	60 s	VRR enabled. RGB 8 BPC. Packets: infoframe_00, infoframe_04 60 frames with changing frame rate: 119 – 80 (1 Hz step), 78 – 40 (2 Hz step), 60 frames with 40 Hz frame rate, 60 frames with changing frame rate 40 – 79 (2 Hz step), 79 – 119 (1 Hz step). 60 frames with 119 Hz frame rate.
15	UHD VRR 40		VRR enabled. RGB 8 BPC. Packets: infoframe_00, infoframe_04 60 frames with 40 Hz frame rate.
16	UHD VRR 119..40 switch	60 s	VRR enabled. RGB 8 BPC. Packets: infoframe_00, infoframe_04 300 frames with 40 Hz frame rate, 300 frames with 119 Hz frame rate
17	UHD VRR 60	60 s	VRR enabled. RGB 8 BPC. Packets: infoframe_00, infoframe_04 60 frames with 60 Hz frame rate.
18	UHD VRR 60..119 switch	60 s	VRR enabled. RGB 8 BPC. Packets: infoframe_00, infoframe_04 300 frames with 60 Hz frame rate, 300 frames with 119 Hz frame rate.

## Scenarios with Video Mode 3840.2160 60 Hz

Scenarios 19 to 23 are using 3840×2160 59.94/60 video timing (VIC 97). No audio.

	Name	Duration	Repeated sequence
19	UHD No VRR 59	60 s	VRR disabled. RGB 8 BPC. Packet: infoframe_02
20	UHD VRR 40	60 s	VRR enabled. RGB 8 BPC. Packets: infoframe_00, infoframe_02 60 frames with 40 Hz frame rate.
21	UHD VRR 40..59 switch	60 s	VRR enabled. RGB 8 BPC. Packets: infoframe_00, infoframe_02 300 frames with 40 Hz frame rate, 300 frames with 59 Hz frame rate.
22	UHD VRR 59..40	60 s	VRR enabled. RGB 8 BPC. Packets: infoframe_00, infoframe_02 60 frames each with changing frame rate: 59, 52, 50, 48, 46, 45, 44, 43, 42, 41, 40, 41, 43, 45, 47, 49, 51, 53, 54, 55, 56, 57, 58 (Hz).
23	UHD VRR 59..40 steps	60 s	VRR enabled. RGB 8 BPC. Packets: infoframe_00, infoframe_02 29 frames with changing frame rate: 59 – 41, 10 frames with 40 Hz frame rate, 29 frames with changing frame rate 41 – 59, 40 frames with 60 Hz frame rate.

## Playlist: Frame Rate Example (DP)

Playlist for demonstrating use of multiple frame rates with FHD and UHD resolution when using DisplayPort output.

### Video

The image used for the test contains a combination of color bars, gray scales, and rotating items. The test uses a sequence of images creating a full rotation in 60 frames



### Executed Scenarios

The test is using four scenarios (RGB 8 BPC, No audio)

	Name	Duration	Repeated sequence
1	Spinners FHD 59fps	60 s	1920×1080 59.94/60 Hz video timing (VIC 16), 60 frames 'colorBarsSpinning-X.svg' X= 0 to 59
2	Spinners FHD 119fps	60 s	1920×1080 119.88/120 Hz video timing (VIC 63), 60 frames 'colorBarsSpinning-X.svg' X= 0 to 59
3	Spinners UHD 59fps	60 s	3840×2160 59.94/60 Hz video timing (VIC 97) 60 frames 'colorBarsSpinning-X.svg' X= 0 to 59
4	Spinners UHD 119fps	60 s	3840×2160 119.88/120 Hz video timing (VIC 120) 60 frames 'colorBarsSpinning-X.svg' X= 0 to 59

## Playlist: ALLM (HDMI)

Playlist for demonstrating Auto Low-latency Mode (ALLM) capability of a DUT monitor.

### Video:

The Scenarios use a series of images: allm\_on\_off\_000.jpg to allm\_on\_off\_0011.jpg. Text panel on the images indicate if ALLM is enabled or not. The first scenario is presented with ALLM enabled and the second by switching ALLM on and off sequentially.



### Scenarios for HDMI Output

Video mode in all steps: CTA 1920×1080 60 Hz (VIC 16), RGB 8 BPC, No audio.

Name	Duration	Repeated sequence
ALLM Static	60 sec	10 frames allm_on_off_000.jpg, Packet: allm_0.bin; 10 frames allm_on_off_001.jpg, Packet: allm_0.bin; 10 frames allm_on_off_002.jpg, Packet: allm_0.bin; 10 frames allm_on_off_003.jpg, Packet: allm_0.bin; 10 frames allm_on_off_004.jpg, Packet: allm_0.bin; 10 frames allm_on_off_005.jpg, Packet: allm_0.bin
ALLM Toggle	60 sec	10 frames allm_on_off_000.jpg, Packet: allm_0.bin; 10 frames allm_on_off_001.jpg, Packet: allm_0.bin; 10 frames allm_on_off_002.jpg, Packet: allm_0.bin; 10 frames allm_on_off_003.jpg, Packet: allm_0.bin; 10 frames allm_on_off_004.jpg, Packet: allm_0.bin; 10 frames allm_on_off_005.jpg, Packet: allm_0.bin; 10 frames allm_on_off_006.jpg, Packet: allm_1.bin; 10 frames allm_on_off_007.jpg, Packet: allm_1.bin; 10 frames allm_on_off_008.jpg, Packet: allm_1.bin; 10 frames allm_on_off_009.jpg, Packet: allm_1.bin; 10 frames allm_on_off_0010.jpg, Packet: allm_1.bin; 10 frames allm_on_off_0011.jpg, Packet: allm_1.bin